

# Installation Instructions and Operation & Maintenance Manual

## DuraDuct™ GNX

2-Hour Zero Clearance Ventilation Duct System

Do not install this system without completely reading the installation instructions. All details as noted in this document must be followed. For further information please contact VaughanAir. Not to be used in commercial kitchen exhaust applications.

Pennsylvania Avenue ■ Concord, ON L4K 4A6, Canada  
TEL: 647.946.4770 ■ EMAIL: [sales@vaughanair.com](mailto:sales@vaughanair.com)



## CONTENTS

<b>GENERAL INFORMATION .....</b>	<b>2</b>
Product Features: .....	2
Testing Standards Performed: .....	3
Design Listing Information: .....	3
Code Compliance: .....	3
<b>CONSTRUCTION DETAILS.....</b>	<b>4</b>
.....	4
Typical Fitting Details: .....	5
Connection Details: .....	6
<b>SUPPORT METHODS AND DETAILS.....</b>	<b>7</b>
Horizontal Supports: .....	7
DuraDuct™ GNX Horizontal Duct Support Chart: .....	7
Vertical Supports: .....	8
DuraDuct™ GNX Support Suspended From Slab Chart:.....	8
DuraDuct™ GNX Vertical Slab Support Chart: .....	9
DuraDuct™ GNX Knee Bracket Support Chart:.....	10
<b>THROUGH-PENETRATION FIRESTOP SYSTEM .....</b>	<b>11</b>
Horizontal Firestop:.....	11
Vertical Firestop: .....	12
<b>ADDITIONAL FEATURES .....</b>	<b>13</b>
Dampers: .....	13
GNX R-Value: .....	13
<b>HANDLING &amp; MAINTENANCE .....</b>	<b>14</b>
Handling Instructions:.....	14
Maintenance Guidelines: .....	14
Warranty: .....	14

## GENERAL INFORMATION

DuraDuct™ GNX is a segmented, pre-manufactured, non-combustible fire resistance rated ventilation duct system. It uses a patented double wall construction that is lightweight and impact resistant. DuraDuct™ GNX is a zero-clearance system to all combustible and non-combustible materials. By using a flange-to-flange connection, the system design is familiar to installing contractors and is provided in a square/rectangular footprint. The system is fully customizable to allow flexibility in the design of the duct system.

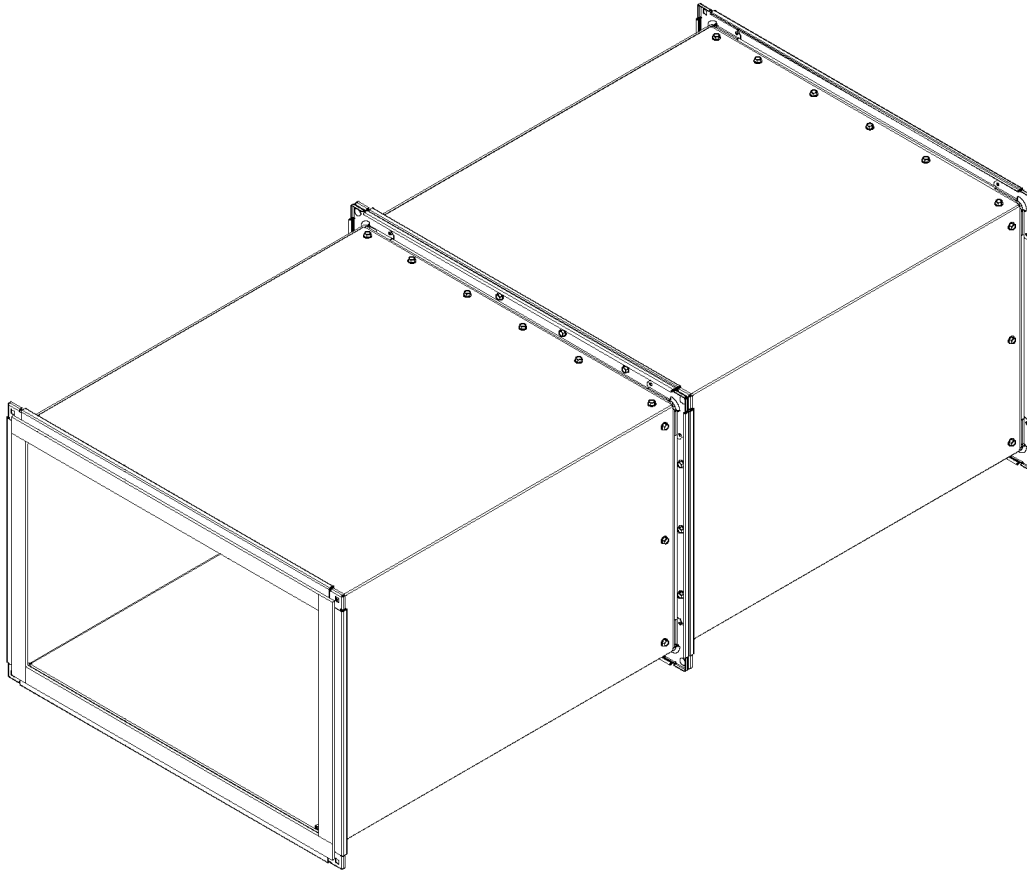

### PRODUCT FEATURES:

- Zero Clearance to combustibles at any location
- Listed to code compliant standard ASTM E119
- Easy to install flange to flange connections
- Thin footprint; 7/8" thick double wall design
- Mechanical protection of the insulating material inherent in the design
- All materials are inorganic and non-combustible
- Specialized fittings available
- UL 555 Damper and Sub-duct options available
- Standard R-Value of R4.5

## TESTING STANDARDS PERFORMED:

ASTM E119	Standard Test Methods for Fire Tests of Building Construction and Materials
CAN/ULC-S101	Standard Methods of Fire Endurance Tests of Building Construction and Materials
ASTM E814	Standard Test Method for Fire Tests of Through-Penetration Fire Stops
CAN/ULC-S115	Standard Method of Fire Tests of Firestop Systems

## DESIGN LISTING INFORMATION:

- DuraDuct™ GNX is listed for vertical applications by Intertek:
  - Listing numbers DSB/FMF 120-04 & DSB/FMF 120-05.
  
- DuraDuct™ GNX is listed for horizontal applications by Intertek:
  - Listing numbers DSB/FMF 120-06 & DSB/FMF 120-07

## CODE COMPLIANCE:

National Building Code of Canada:

- CAN/ULC-S101 Listed
- CAN/ULC-S115 Listed

International Mechanical Code, International Building Code:

- ASTM E119 Listed
- ASTM E814 Listed

## CONSTRUCTION DETAILS

DuraDuct™ GNX has a 7/8" annular space between the inner liner and outer casing. It is constructed with a standard galvanized steel inner liner and the outer casing of the system is supplied with a standard galvanized steel construction. Optional materials, including satin coat and stainless steel can be provided upon request. DuraDuct™ GNX is supplied with flange-to-flange connections and all screws, nuts, bolts and gaskets to complete the connections.

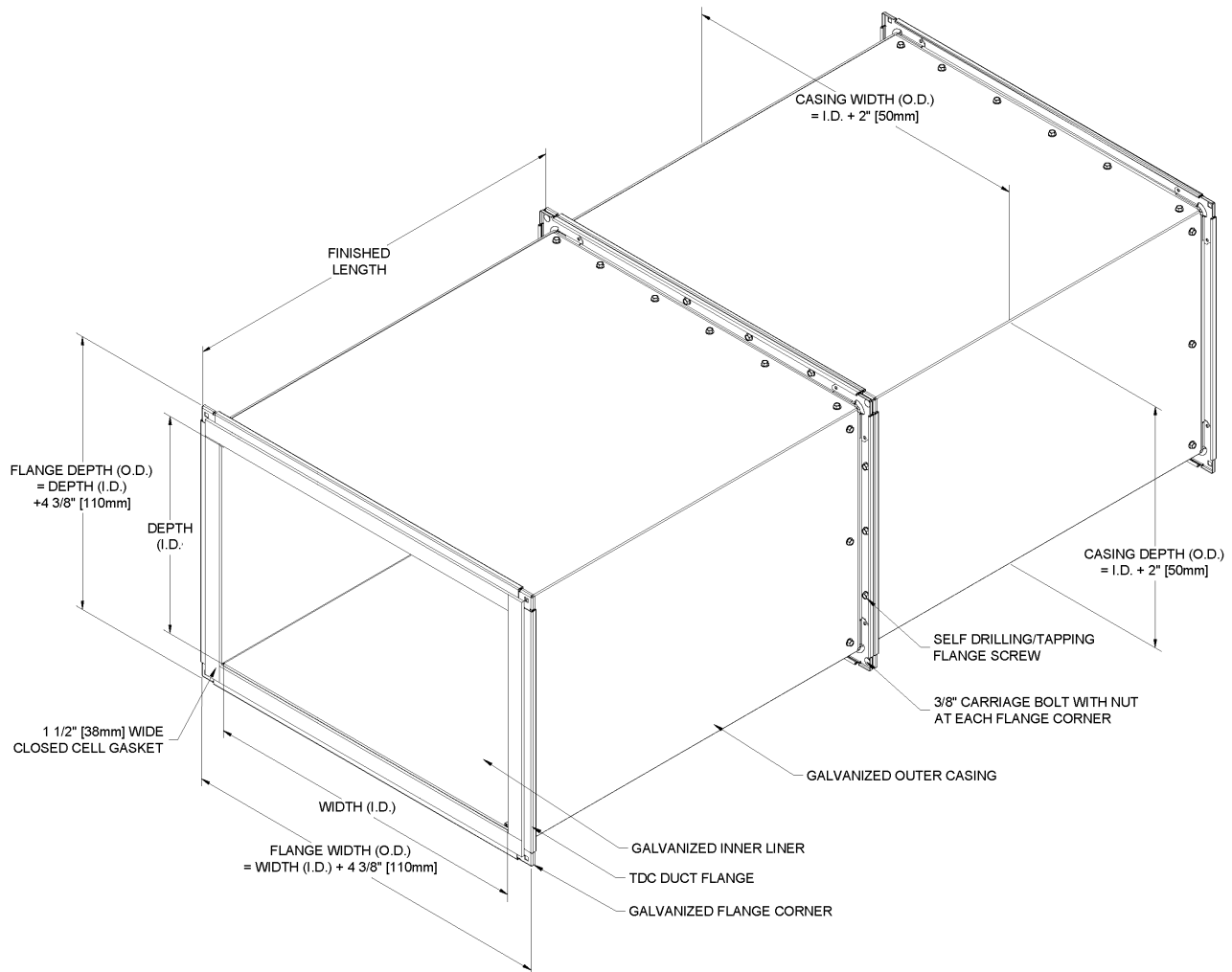

**\*NOTE:** DuraDuct™ GNX weight = 4 lbs/sq.ft.

## TYPICAL FITTING DETAILS:

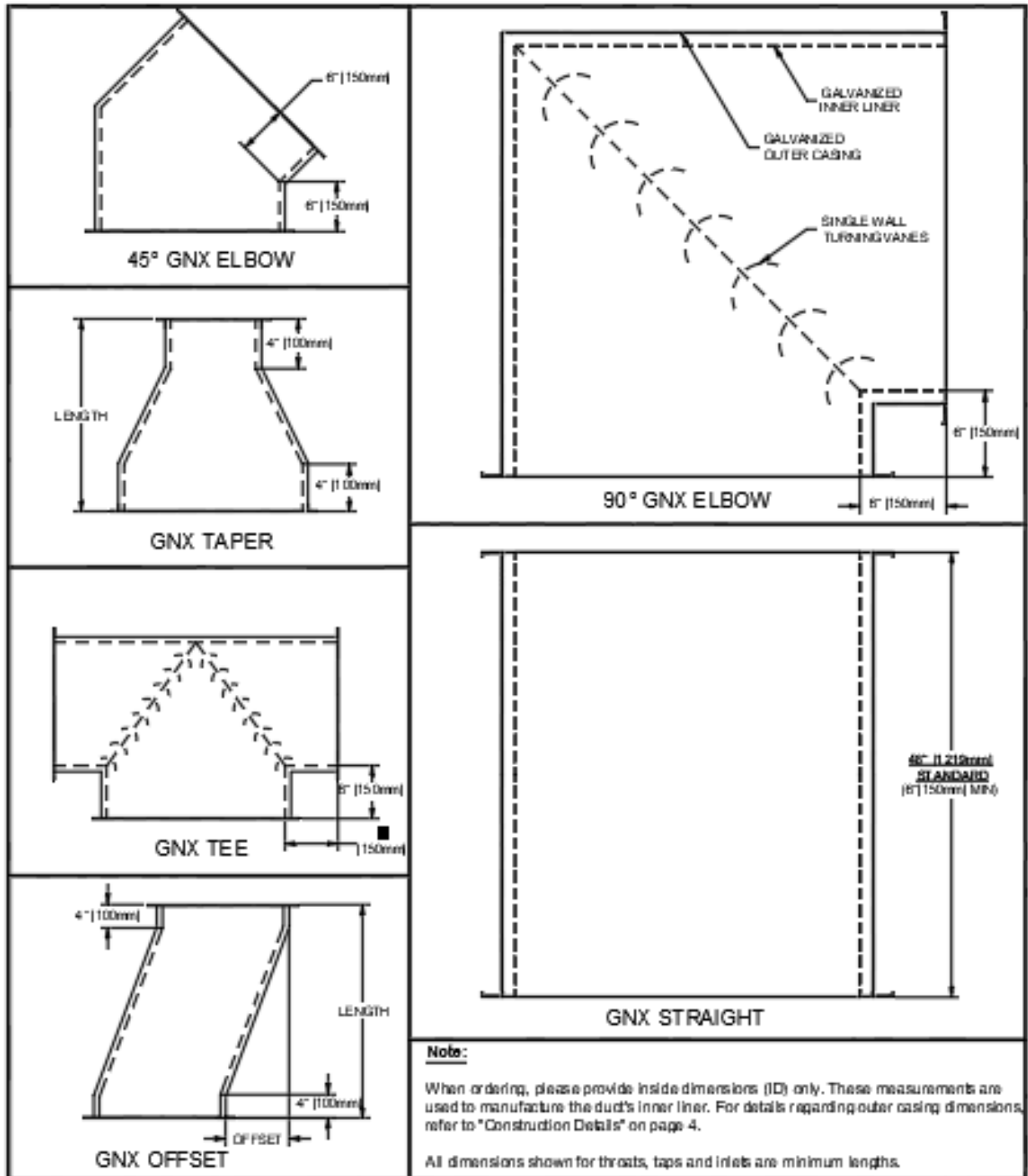

\* Allow for growth due to gasket of 1/4" per joint.

\*\*NOTE: Custom duct fittings are available upon request. Contact VaughanAir to coordinate.

## CONNECTION DETAILS:

All duct sections are supplied with flanged connections. All flanged connections are designed alike providing a quick and trouble-free installation. All flange gaskets, nuts, bolts, washers and screws are provided to complete the single-source design. Assembly details follow.

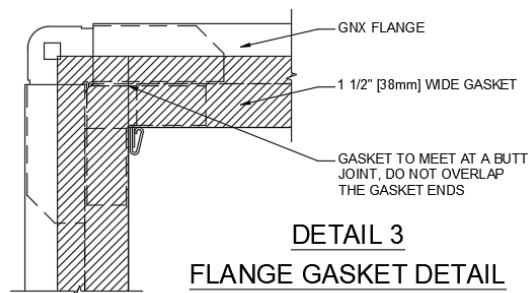
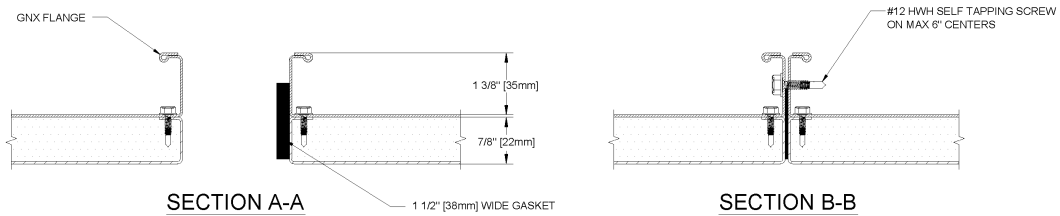
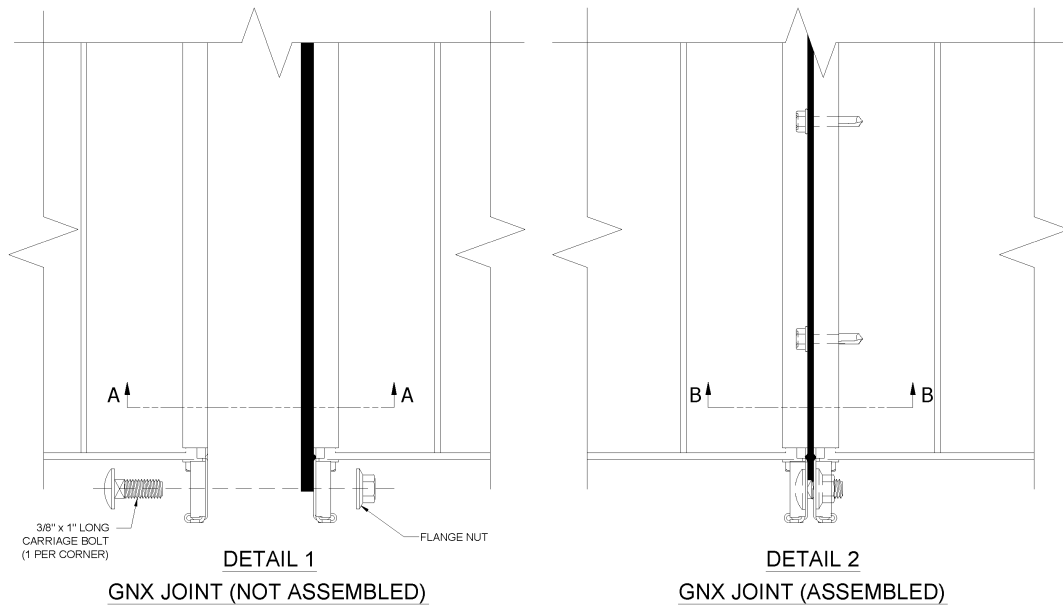

## SUPPORT METHODS AND DETAILS

### HORIZONTAL SUPPORTS:

The horizontal supports will provide for joint alignment and support for ventilation duct horizontal applications. Spacing as noted in the chart is required. The horizontal supports shall be secured to fire resistance rated structural members of the building, which can adequately support the weight of the duct system. The duct cradles are based on support rods being a maximum of 1" from the side of the duct. Consult VaughanAir if the support rods are to be installed further from the duct than noted prior to installation.

### DURADUCT™ GNX HORIZONTAL DUCT SUPPORT CHART:

Duct width	Duct height	Unistrut size	Steel angle size	Rod size	Embed. Depth	Spacing
24"	24"	P2000 Unistrut	L1.5x1.5x1/8	3/8"	1 5/8"	4 ft.
36"	36"	P2000 Unistrut	L1.5x1.5x3/16	1/2"	2 1/4"	4 ft.
42"	42"	P2000 Unistrut	L1.5x1.5x3/16	1/2"	2 1/4"	4 ft.
60"	48"	P2000 Unistrut	L1.5x1.5x1/4	1/2"	2 1/4"	4 ft.
72"	36"	P1000 Unistrut	L1.5x1.5x1/4	1/2"	2 1/4"	4 ft.
84"	24"	P5500 Unistrut	L2x2x1/4	1/2"	2 1/4"	4 ft.

#### Notes:

- 1) Unistrut channels are based on A653 grade 33 steel with a minimum 33 ksi yield strength.
- 2) Steel angles are based on formed A653 grade 33 steel with a minimum 33 ksi yield strength.
- 3) Vertical rods are based on 36 ksi yield strength.
- 4) Vertical rod location shall be maximum 1" from the outside wall of the duct.
- 5) Anchors to be drop-in or wedge type anchors installed with minimum embedment as shown above.
- 6) All supports are contractor supplied.
- 7) Contact VaughanAir when project support requirements vary from what is shown, or anchorage is into concrete on metal decking.

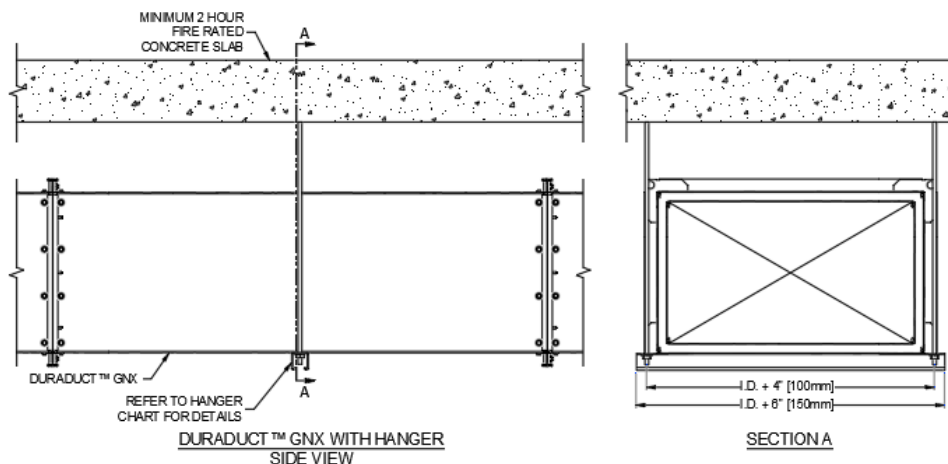

Cradle/Rod Locations



## VERTICAL SUPPORTS:

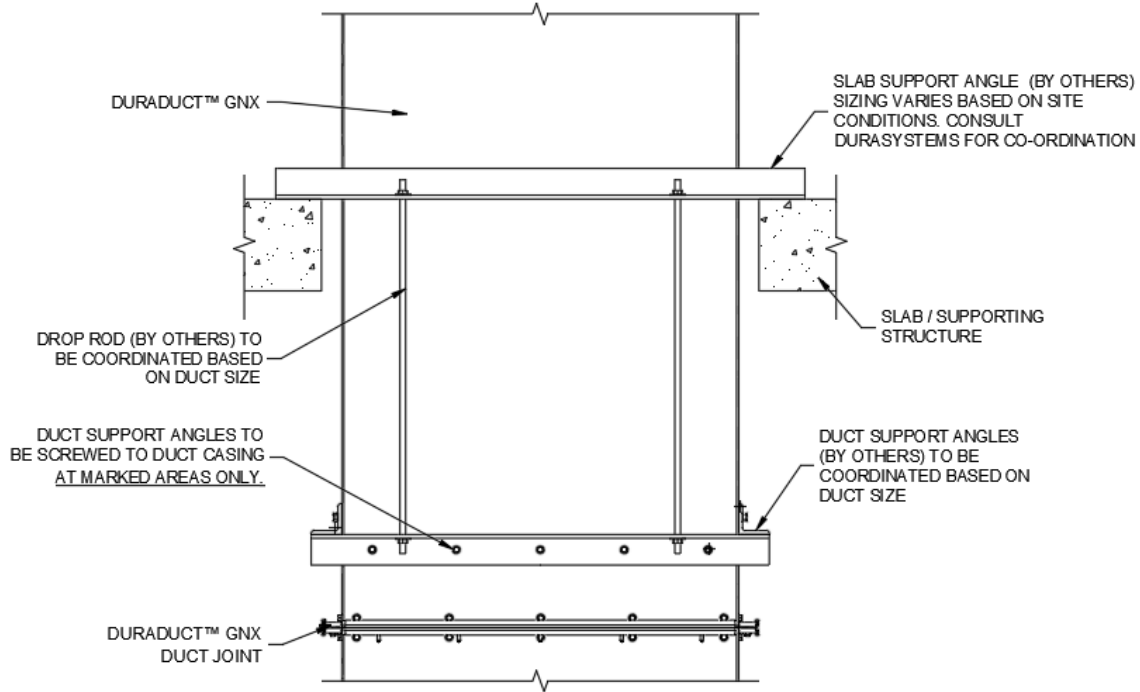

**Typical Support Suspended From Slab** - Floor supports must overlap the edge of the opening by a minimum of 3". The floor supports shall sit on a structural slab or to fire resistance rated structural members of the building, which can adequately support the weight of the ventilation duct system. See below for general installation details and contact VaughanAir for support and rod dimensions.

### DURADUCT™ GNX SUPPORT SUSPENDED FROM SLAB CHART:

Duct width	Duct depth	Screw size	Screw centers	Lower member	Vertical limit	Rod size	Upper member
24	24	1/4"	8"	L2x2x1/4	15 ft.	3/8"	L2.5x2.5x3/8
36	36	1/4"	8"	L2.5x2.5x1/4	15 ft.	1/2"	L3x3x3/8
42	42	1/4"	8"	L2.5x2.5x3/8	15 ft.	1/2"	L3x3x3/8
60	48	1/4"	8"	L3x3x3/8	15 ft.	1/2"	L3.5x3.5x3/8
72	36	1/4"	8"	L2.5x2.5x3/8	15 ft.	1/2"	L3.5x3.5x3/8
84	24	1/4"	8"	L2x2x3/8	15 ft.	1/2"	L3.5x3.5x3/8

#### Notes:

- 1) Steel angles are based on formed A653 grade 33 steel with a minimum 33 ksi yield strength.
- 2) Edge of slab shall be maximum 2-1/4" from each side of the duct casing.
- 3) Vertical rods are based on 36 ksi yield strength.
- 4) All supports are contactor supplied.

**Typical Support On Slab** - Floor supports must overlap the edge of the opening by a minimum of 2". The floor supports shall sit on a structural slab or to fire resistance rated structural members of the building, which can adequately support the weight of the ventilation duct system. See below for installation details.

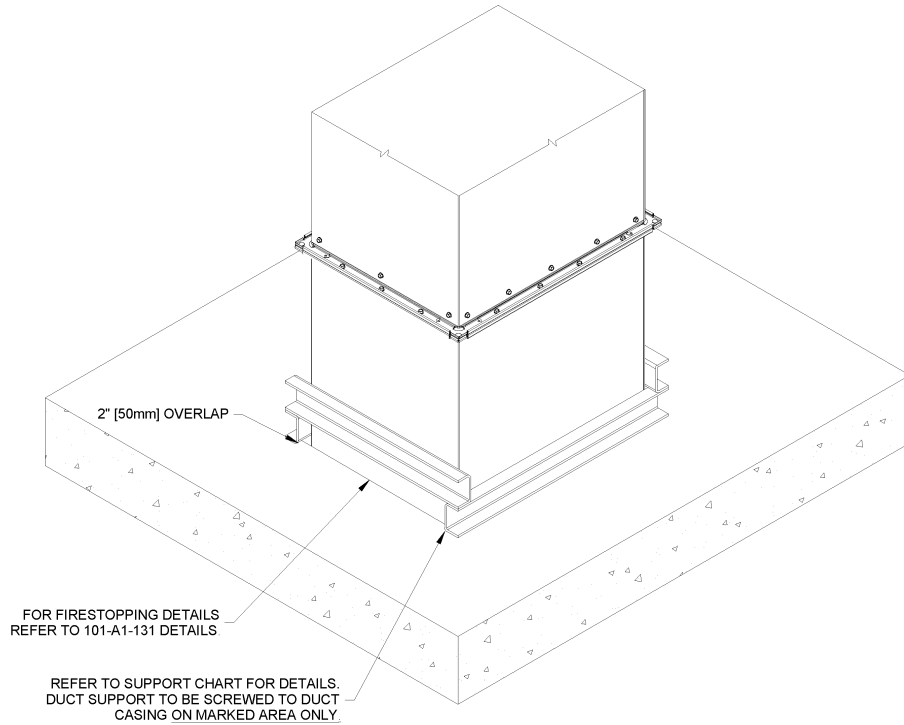

## DURADUCT™ GNX VERTICAL SLAB SUPPORT CHART:

Maximum inside duct dimension	Support channel	Screw size	Screw centers	Vertical limit
24"	C2x3x2, 14ga	1/4"	8"	15 ft.
36"	C2x3x2, 1/4"	1/4"	8"	15 ft.
42"	C2x3x2, 1/4"	1/4"	8"	15 ft.
60"	C2x4x2, 1/4"	1/4"	8"	15 ft.
72"	C2x4.5x2, 1/4"	1/4"	8"	15 ft.
84"	C2x5x2, 1/4"	1/4"	8"	15 ft.

### Notes:

- 1) Channels are based on formed A653 grade 33 steel with a minimum 33 ksi yield strength.
- 2) Edge of slab shall be maximum 2-1/4" from each side of the duct casing.
- 3) All supports are contactor supplied.

**Note:** Please contact VaughanAir if duct supports are to deviate from the guidelines listed above for review prior to installation.

**Knee Bracket To Wall** - The knee brackets should maintain a 30° angle, if this impractical consult with VaughanAir prior to installation. The vertical supports shall be secured to fire resistance rated structural members of the building, which can adequately support the weight of the ventilation duct system. See below for installation details.

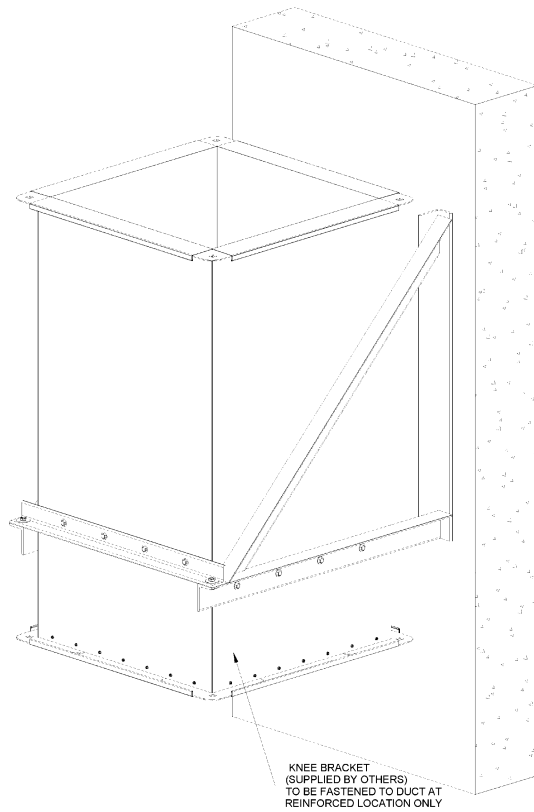

## DURADUCT™ GNX KNEE BRACKET SUPPORT CHART:

Duct depth	Duct width	Screw size	Screw centers	Support angle	Vertical limit
24	24	1/4"	6"	L2x2x1/4"	15 ft.
36	36	1/4"	6"	L2.5x2.5x1/4"	15 ft.
42	42	1/4"	6"	L2.5x2.5x3/8"	15 ft.
48	60	1/4"	6"	L3x3x3/8"	15 ft.
36	72	1/4"	6"	L2.5x2.5x3/8"	15 ft.
24	84	1/4"	6"	L2x2x3/8"	15 ft.

### Notes:

- 1) Contact VaughanAir for assistance with anchor size, quantity and embedment depth.
- 2) All supports are contactor supplied.

**Note:** Please contact VaughanAir if duct supports are to deviate from the guidelines listed above for review prior to installation.

## THROUGH-PENETRATION FIRESTOP SYSTEM

THE FIRESTOPPING OF PENETRATIONS IS AN INTEGRAL PART OF OUR DUCT LISTINGS AND THE ENSUING DETAILS MUST BE FOLLOWED. ALL PENETRATIONS THROUGH FIRE RATED WALLS AND FLOORS MUST BE FIRESTOPPED AS SHOWN.

### HORIZONTAL FIRESTOP:

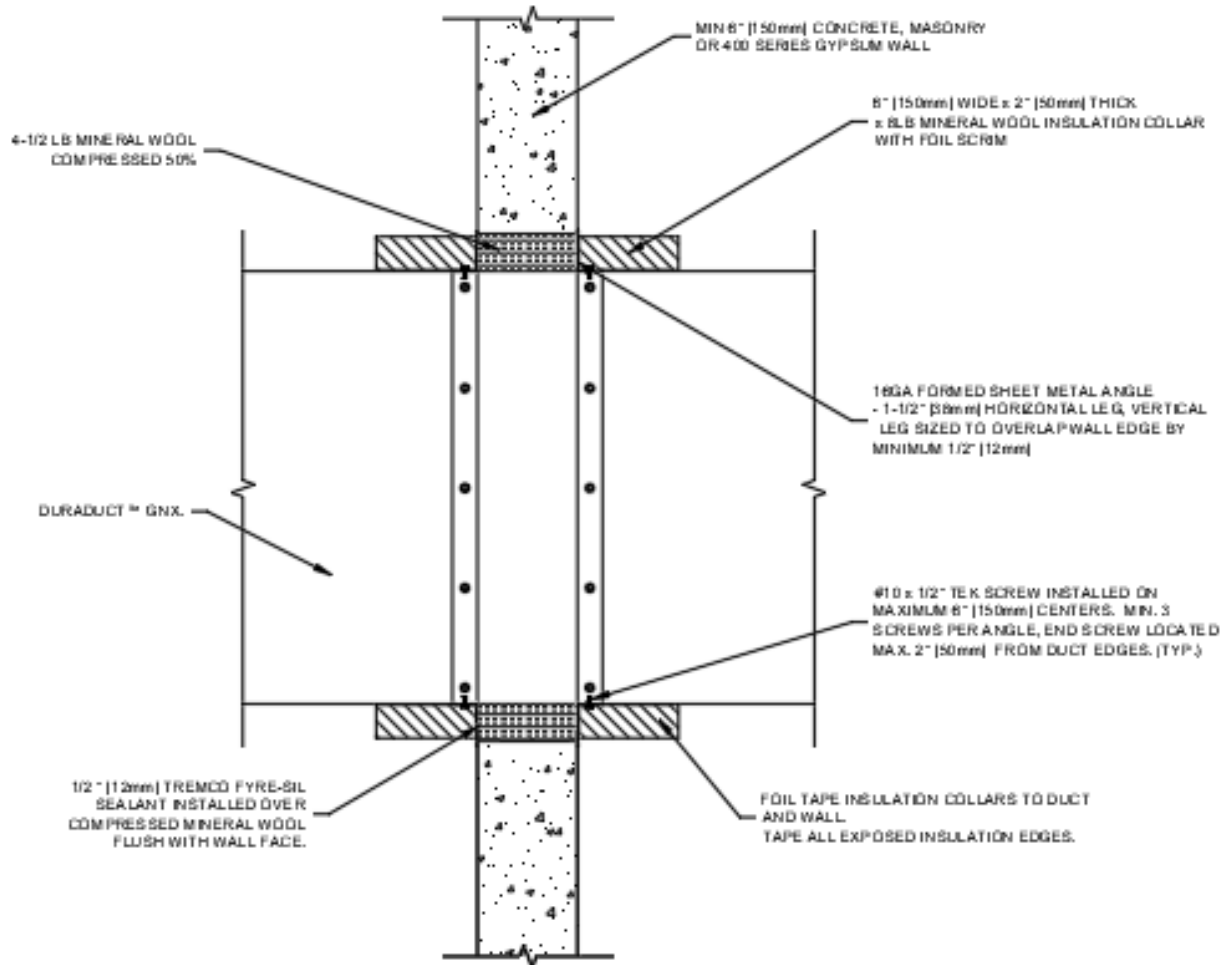

Typical Firestop Detail through a Gypsum or Concrete Wall

**Insulation Collar Installation** - Use 12 GA, steel pins and minimum 1-1/2" steel self-locking pin washers (clips) to secure collar to the duct. Install on maximum 20" centers and 3" from edge of the duct using #10 TEK screws. Apply aluminum foil tape to seal edge of collar to the duct.

## VERTICAL FIRESTOP:

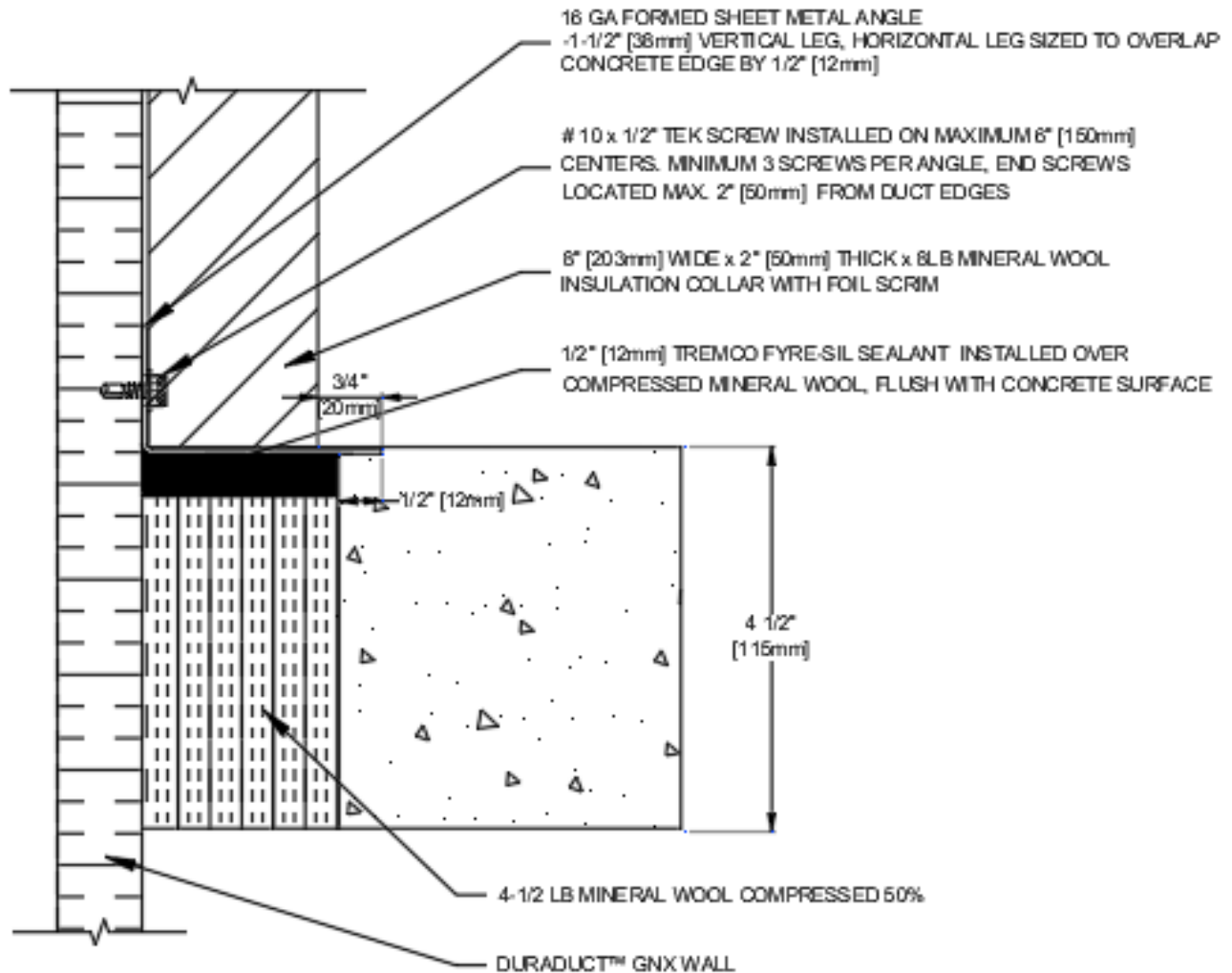

Typical Firestop Detail through floor assembly

**Insulation Collar Installation** - Use 12 GA, steel pins and minimum 1-1/2" steel self-locking pin washers (clips) to secure collar to the duct. Install on maximum 20" centers and 3" from edge of the duct using #10 TEK screws. Apply aluminum foil tape to seal edge of collar to the duct.

**Note:** Please contact VaughanAir if the firestop must deviate from the guidelines listed above for review prior to installation.

## ADDITIONAL FEATURES

### DAMPERS:

Dampers should be listed to UL 555 or CAN/ULC-S112 for their intended use. The installation shall be in accordance with the DuraDuct™ GNX listing. The UL 555 or CAN/ULC-S112 dampers can be factory installed and supplied to site pre-assembled or field installed.

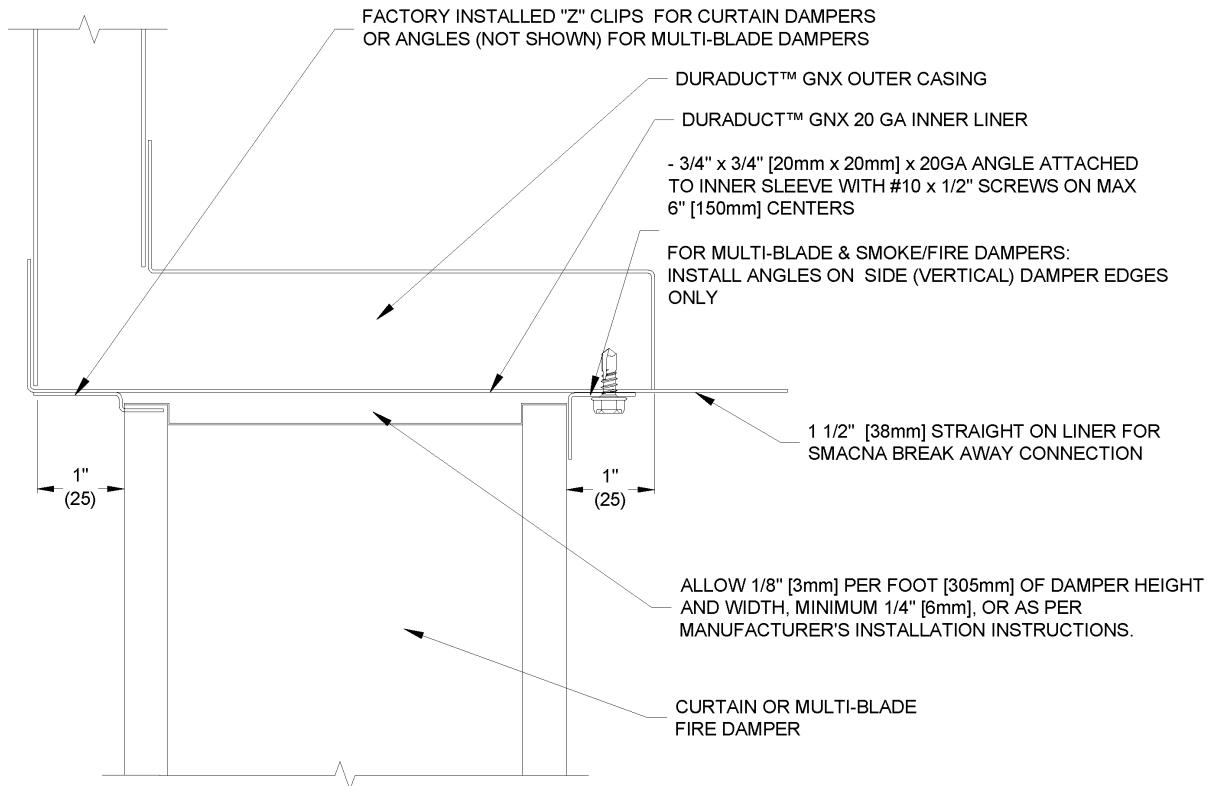

**\*Note:** Although DuraDuct™ has tested UL 555 and CAN/ULC-S112 dampers as part of the listed assembly, AHJ consultation and approval prior to construction may be required in certain jurisdictions.

**\*Note:** Please contact VaughanAir if the installation will deviate from the guidelines listed above for review prior to installation.

### GNX R-VALUE:

Standard GNX offers an R-Value of R4.5. If an R-Value exceeding this value is required for a specific project condition, please contact VaughanAir with details.

## HANDLING & MAINTENANCE

### HANDLING INSTRUCTIONS:

DuraDuct™ GNX is a robust system, however, care should be taken in handling the ductwork. All fittings are shipped skidded and shrink wrapped. Each component should be inspected for damage. If damage has occurred:

- Notify VaughanAir and the freight company upon receipt of the goods.
- Record damaged items on the bill of lading.
- Send pictures of damaged items to VaughanAir.
- Do not store outside unless protected.

### MAINTENANCE GUIDELINES:

DuraDuct™ GNX should not require any maintenance after installation under normal use.

### WARRANTY:

These products have a limited lifetime warranty. Please contact VaughanAir or your local representative for further information.



Pennsylvania Avenue ■ Concord, ON L4K 4A6, Canada  
TEL: 647.946.4770 ■ EMAIL: [sales@vaughanair.com](mailto:sales@vaughanair.com)