

Installation Instructions and Operation & Maintenance Manual

DuraDuct KEX

2-Hour Zero Clearance Kitchen Exhaust System
For Interior Applications

Do not install this grease duct system without completely reading the installation instructions. All details as noted in this document must be followed. For further information please contact VaughanAir.

Pennsylvania Avenue ■ Concord, ON L4K 4A6, Canada
TEL: 647.946.4770 ■ EMAIL: sales@vaughanair.com

CONTENTS

GENERAL INFORMATION	3
Product Features:	3
Tests Performed:	4
Standard Method of Fire Resistance Test – Grease Duct Assemblies	4
Standard Method of Fire Tests of Firestop Systems	4
Standard For Factory-Built Grease Ducts	4
Design Listing Information:	4
CONSTRUCTION DETAILS.....	4
Code Compliance:	13
Handling & Storage Instructions:	13
Connection Details:	14
Flange Assembly Instructions:	14
Common Duct (Manifold) Systems:	16
Dampers:	16
ACCESS DOOR DETAILS.....	17
VaughanAir Zero Clearance Access Doors Features:	17
SUPPORT METHODS AND DETAILS.....	18
Horizontal Supports:	18
Slope Requirements:	19
Vertical Supports:	19
Lateral Guide Supports	20
Floor Supports	21
THROUGH-PENETRATION FIRESTOP SYSTEM	22
TERMINATIONS	24
FAN CONNECTIONS/HOOD ADAPTORS	24
Hood Connections:	25
ROOF PENETRATIONS	26
Roof penetration through curb:	26

FIRE PROTECTION & MAINTENANCE 26

- Duct Testing: 26
- Sprinkler Head Access Port detail for fire extinguishing systems: 26
- Drain Section Detail:..... 27
- Maintenance Guidelines: 27
- Cleaning Procedure:..... 28
- Access Door Removal/Replacement instructions: 28
- Test Port Detail: 29

WARRANTY 29

GENERAL INFORMATION

DuraDuct KEX is a segmented, pre-manufactured, and non-combustible double wall grease duct system. Model KEX is a zero-clearance system to all combustible and non-combustible materials in accordance with NFPA 96 4.3.6.1. By using a flange-to-flange connection, the system will eliminate the need for field welding of code compliant grease duct systems and provide a rectangular footprint to allow flexibility in the design of the exhaust ductwork in Type I and Type II grease duct systems.

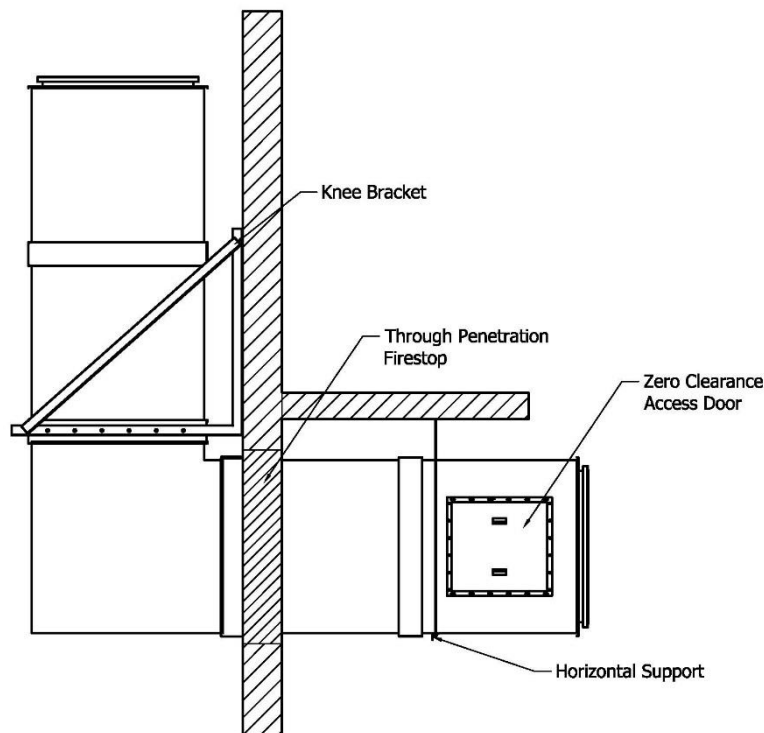

General Layout Detail

PRODUCT FEATURES:

- Zero Clearance to combustibles at any location
- No weld system: flange to flange connections
- Thin footprint; 3-1/4" double wall design
- Mechanical protection of the insulating material inherent in the design, meets NFPA 96 Clause 4.3.2
- All materials are inorganic and non-combustible
- Built-in, listed and NFPA 96 complaint zero clearance grease duct access doors
- 16-gauge steel or 18-gauge stainless steel fully welded inner duct liner
- Specialized fittings available

TESTS PERFORMED:

ASTM E 2336	Standard Test Methods for Fire Resistive Grease Duct Enclosure Systems
ASTM E 119	Standard Test Methods for Fire Tests of Building Construction and Materials
ASTM E 814	Standard Test Method for Fire Tests of Through-Penetration Fire Stops
ASTM E 136	Standard Test Method for Behavior of Material in a Vertical Tube Furnace at 750°C (1382°F)
ASTM C 518	Standard Test Method for Steady-State Thermal Transmission Properties by Means of the Heat Flow Meter Apparatus
ASTM E 84	Standard Test Method for Surface Burning Characteristics of Building Materials
UL 1978	UL Standard for Safety for Grease Ducts
CAN/ULC-S144	Standard Method of Fire Resistance Test – Grease Duct Assemblies
CAN/ULC-S115	Standard Method of Fire Tests of Firestop Systems
CAN/ULC-S662	Standard For Factory-Built Grease Ducts

DESIGN LISTING INFORMATION:

DuraDuct KEX is listed in accordance with ASTM E2336 and CAN/ULC-S144 by Intertek listing number DSB/FMF 120-01. DuraDuct KEX is also certified in accordance with ICC-ES AC-101.2 and verified as IMC code compliant by Intertek Code Compliance Report, CCRR-1046.

CONSTRUCTION DETAILS

DuraDuct KEX has a 3-1/4" annular space between the inner liner and outer casing. It is constructed with a 16-gauge steel or 18-gauge stainless steel inner liner and 20-gauge galvanized or 22-gauge stainless steel outer casing construction. It is supplied with flange-to-flange connections and a field applied flange cover assembly.

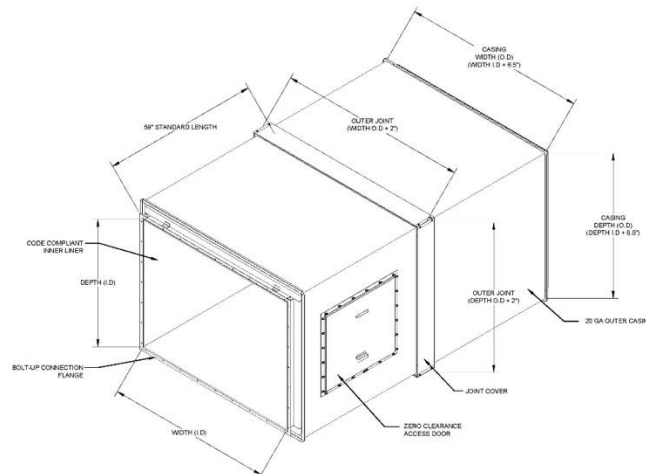

General Construction Detail

- Materials:**
- Inner Liner: 16ga C.R. steel - Standard
18ga 304 Stainless steel - Premium
18ga 316 Stainless steel - Premium
 - Outer Casing: 20ga Galvanized steel - Standard
22ga 304 Stainless steel - Premium
22ga 316 Stainless steel - Premium

- Angle Flanges:**
- 11/2" x 1/8" Hot rolled steel structural angle - Standard
 - 11/2" x 1/8" 304 Stainless steel structural angle - Premium
 - 11/2" x 1/8" 316 Stainless steel structural angle – Premium

- Duct Weight:**
- 10 lbs/ft²

- Standard Fittings:**
- See the attached pages for DuraDuct KEX standard fittings and dimensions.
 - Non-Standard fittings, fittings sizes, and fitting configurations are available for a premium. Contact VaughanAir for details.

- Construction**
- Inner Duct (**A**)
 - Casing (**B**) = A + 6.5"
 - O.D at Joint (**C**) = A + 8.5

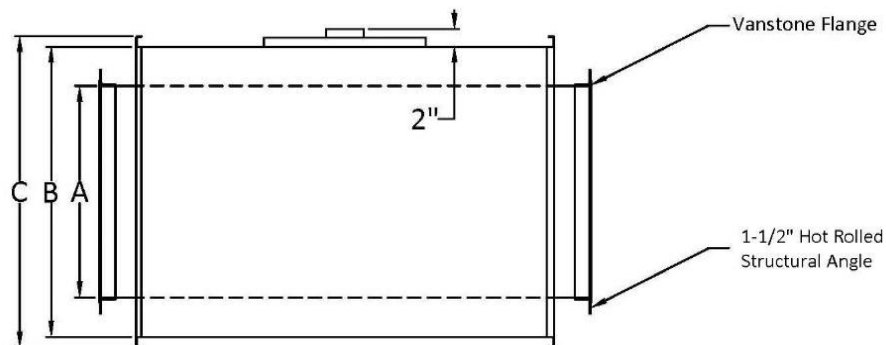

DuraDuct KEX Construction Detail

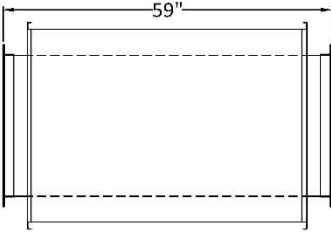
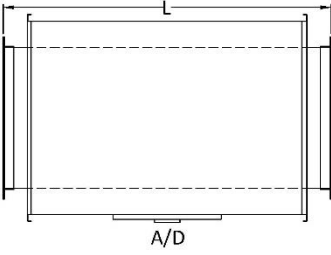
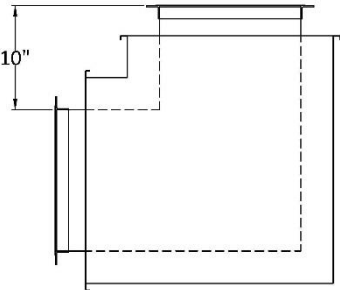
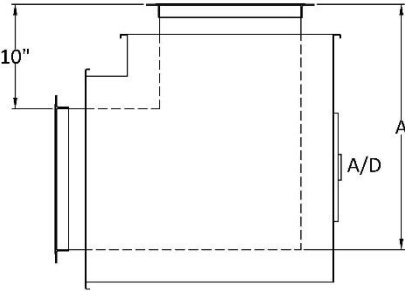
	<p>Straight Duct</p> <p>Standard Length = 59"</p>
	<p>Straight With Access Door</p> <p>Minimum Length with access door (L) = 36" Minimum Length without access door (L) = 14" ** Duct lengths shorter than 14" should be added to adjacent fitting.</p>
	<p>90 Degree Square Elbow</p> <p>Standard Throat = 10"</p>
	<p>90 Degree Square Elbow with Access Door</p> <p>Standard Throat = 10" Minimum Heel Length (A) = 20"</p>

	<p>90 Degree Radius Elbow</p> <p>Standard Throat = 10" Standard Radius = W</p>
	<p>45 Degree Elbow</p> <p>Standard Throat = 10"</p>
	<p>45 Degree Elbow with Access Door</p> <p>Standard Throat = 10" Minimum heel length for access door (A) = 22"</p>

	<p>Straight Duct with Tap</p> <p>Standard Throat = 10" Length (L) = W2+20" Minimum length with access door (L) = 24"</p>
	<p>Transition</p> <p>Standard length (L) = 30"</p>
	<p>Transition With Access Door</p> <p>Standard length with access door (L) = 34"</p>

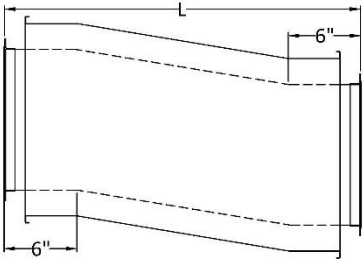
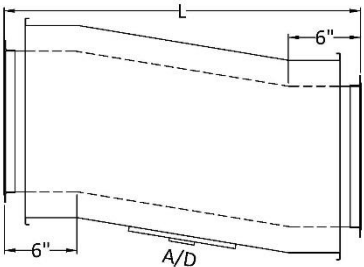
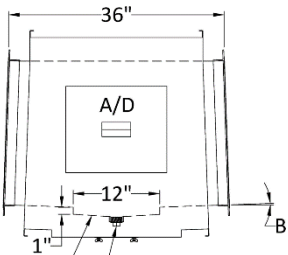
	<p>Offset</p> <p>Standard Length (L) = 30"</p>
	<p>Offset With Access Door</p> <p>Standard Length with access door (L) = 34"</p>
 <p>Grease reservoir full depth of duct 1 1/2" Drain - Capped</p>	<p>Grease Reservoir</p> <p>Standard Length = 36 Slope (B) = 2% for duct runs ≤ 75' = 8% for duct runs > 75"</p> <p>Riser elbows also available in 88 and 82 degree versions to start slope on horizontal duct runs.</p>

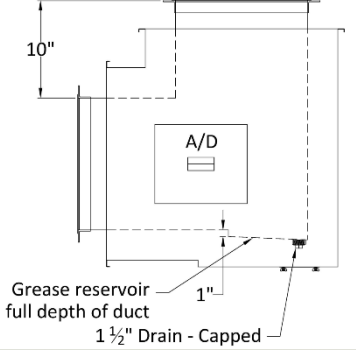
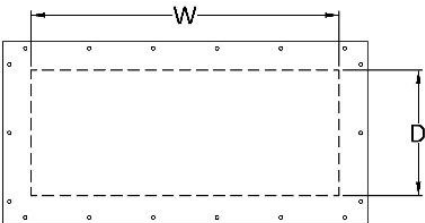
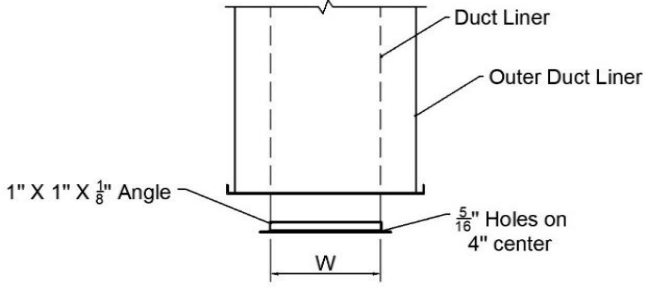
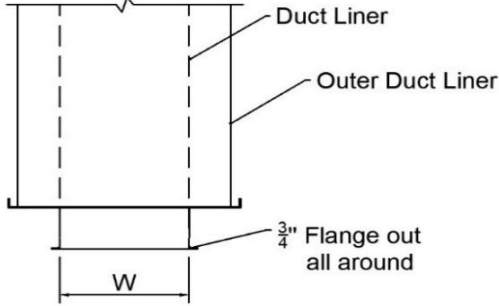
 <p>10"</p> <p>A/D</p> <p>Grease reservoir full depth of duct</p> <p>1"</p> <p>1 1/2" Drain - Capped</p>	<p>Grease Reservoir – Riser</p> <p>Standard Throat = 10"</p>
 <p>W</p> <p>D</p>	<p>Block End</p> <p>W x D = Inner Duct</p>
 <p>Duct Liner</p> <p>Outer Duct Liner</p> <p>1" X 1" X 1/8" Angle</p> <p>5/16" Holes on 4" center</p> <p>W</p>	<p>Bolted Hood Connection</p> <p>W = (I.D of hood flange) - (1/16")</p>
 <p>Duct Liner</p> <p>Outer Duct Liner</p> <p>3/4" Flange out all around</p> <p>W</p>	<p>Welded Hood Connection</p> <p>W = I.D of hood flange SED flange to be field welded of hood flange</p>

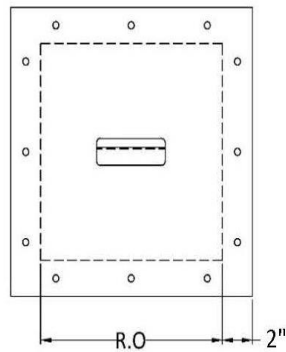

Access Doors

Access doors are located per IMC or NFPA code requirements.

International Mechanical Code (IMC):

A 20"x20" man size access door shall be installed if duct size permits.

Or

12" x 12" access doors shall be installed not more than 20' apart and not more than 10' from changes in direction greater than 45 degrees.

National Fire Protection Association (NFPA):

A 20"x20" man size access door shall be installed if duct size permits.

Or

Access doors shall be installed at 12' intervals and at every change of direction.

Standard Door Opening Sizes (R.O)

12" x 12"	12" x 10"	12" x 8"
12" x 6"	12" x 4 "	12" x 2"
20" x 20"		

CODE COMPLIANCE:

The DuraDuct KEX system, installed as per the ASTM E 2336 design listing, meets the requirements of the following codes: National Building Code of Canada, International Mechanical Code, International Building Code and NFPA 96.

HANDLING & STORAGE INSTRUCTIONS:

DuraDuct KEX is a robust system, however, care should be taken in handling the ductwork. Each component should be inspected for damage. If damage has occurred:

- 1) Notify VaughanAir and the freight company upon receipt of the goods.
- 2) Record damaged items on the bill of lading.
- 3) Send pictures of damaged items to VaughanAir.

All VaughanAir products must be stored in a dry location protected from weather and possible damage from site construction. Exposure to weather or site damage to VaughanAir products may affect product performance and or void the warranty of the product.

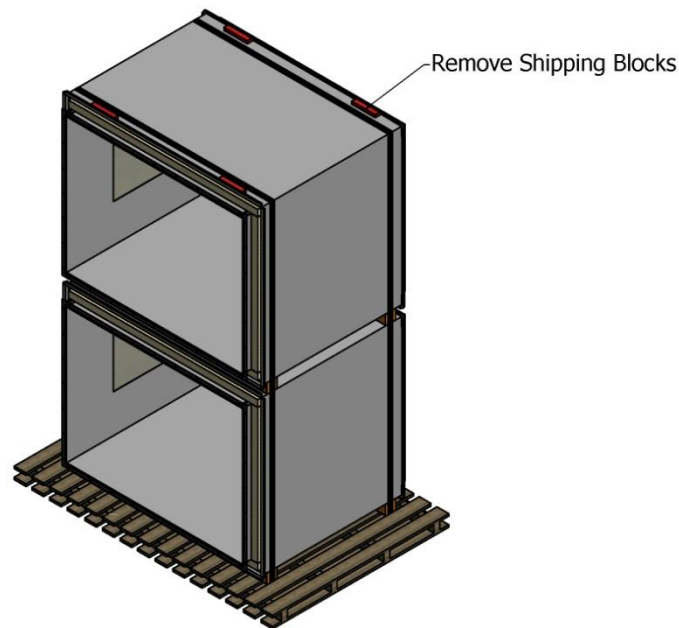

Shipment Configuration

CONNECTION DETAILS:

All components are supplied with flanged connections. All flanged connections are designed alike providing a quick and trouble-free installation. All flange gasket, insulation, sealant, nuts, bolts, washers, and screws are provided to complete the single-source design. Assembly details follow:

FLANGE ASSEMBLY INSTRUCTIONS:

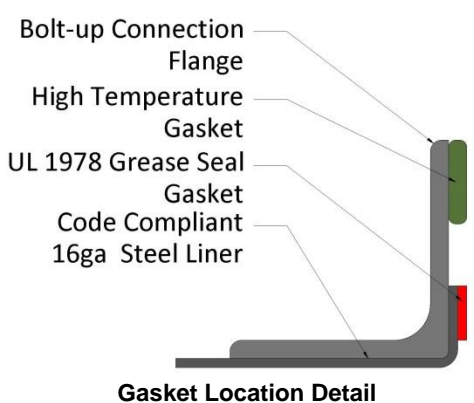
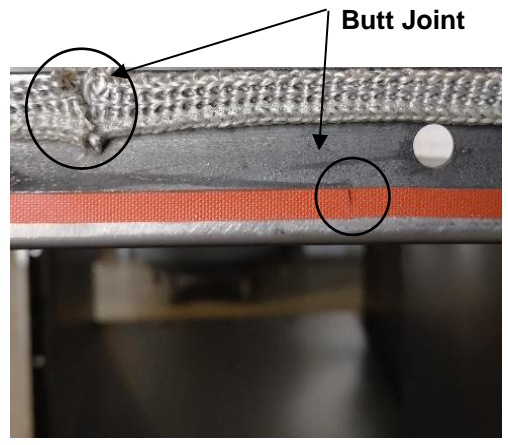
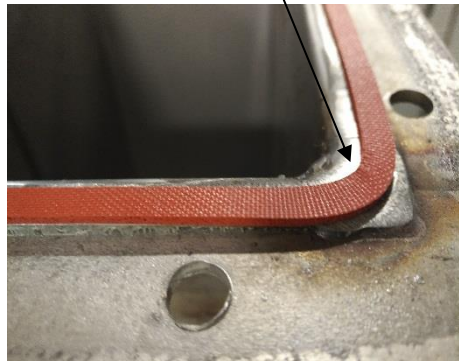
 <p>Gasket Location Detail</p>	 <p>Butt Joint</p> <p>“Butt” Joint Detail</p>
<p>Step 1:</p> <ol style="list-style-type: none"> Thoroughly clean the connection flange of any oil or debris (a solvent-based degreaser may be used) to ensure a positive bond between the gasket and steel flange. Install the grease seal gasket by removing the paper backing and applying the gasket flush to the outer edge of the inner liner flange. Be sure not to stretch the gasket while you apply it to the steel flange. <p><u>Do not install the gasket flush to the inner face of the duct.</u></p> <ol style="list-style-type: none"> Joints and splices should be a butt joint configuration as shown in the “Butt Joint” detail above. <p><u>Locate splices and joints on the top of the duct in horizontal applications. Do not locate joints or splices in the corners of the duct</u></p>	<p>UL 1978 Grease Seal</p> 

- d) Install the high temperature gasket by removing the paper backing and applying the gasket flush to the outer edge of the angle frame.

High Temperature

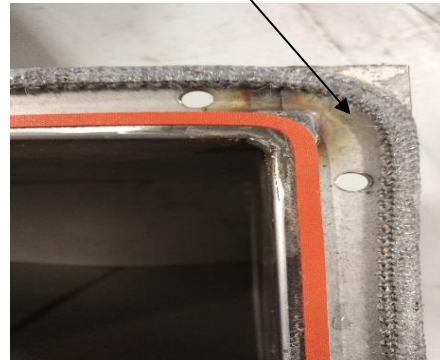

Step 2:

- e) Connect each section using the supplied 5/16" bolt assembly. A nut, bolt and two flat washers are provided for each bolt hole. Tighten each bolt assembly making sure to check each fastener prior to moving on to step 3. Bolt assembly to be torqued to 75 to 95 In-lbf.

Tip: A drift pin is helpful to locate the bolt holes.

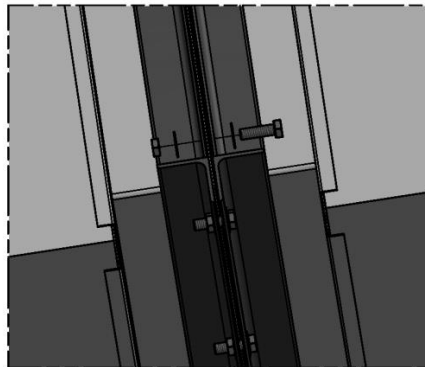

Step: 3

- a) Install the first layer (A), Nominal 4" wide insulation between the internal duct insulation and the inner duct flange. Be sure all voids are filled with insulation. Overlap the vertical and horizontal insulation with a 1/2" compression on each end and stagger to the outside length of the inner duct flanges.
- b) Install the second layer (B), Nominal 8" wide insulation tucked under the duct edges (work the insulation well into the joint and pack down to the flange. Be sure all voids are filled with insulation. Overlap the vertical and horizontal insulation with a 1/2" compression on each end and stagger to the outside length of the inner duct flanges. This insulation layer should overlap the seam in step A.
- c) Install the third layer (C), Nominal 6" wide insulation between the duct edges and into the hat channel. Be sure all voids are filled with insulation. Overlap the vertical and horizontal insulation with a 1/2" compression on each end and stagger to the outer edge of the outer duct casing.

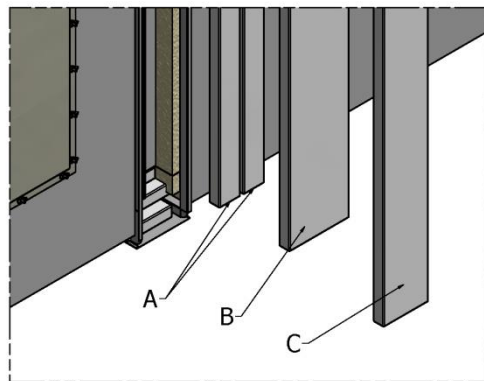

Step: 4

- a) Install the joint cover by sliding the joint cover on to the standing T.

Note: If there is not enough space in the area to slide the joint cover on you may open the hem on one side in order to be able to place the joint cover directly on standing T. Secure the joint cover using #10 x 1/2" long hex head tek screws at max 10" centers.

Consult VaughanAir when duct is to be installed tight to the ceiling.

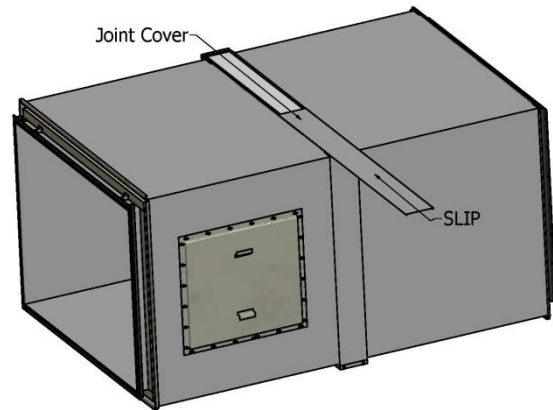

- b) Install corner clips using 4, #10 x 1/2" long hex head tek screws as.

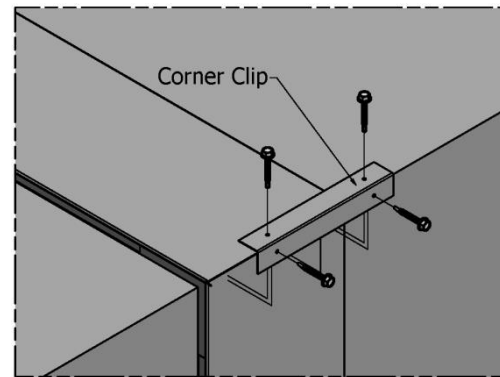

COMMON DUCT (MANIFOLD) SYSTEMS:

DuraDuct KEX is capable of tying together multiple hoods in a single common duct. Make sure to follow the installation drawings closely for specific details regarding these systems.

DAMPERS:

Dampers should be listed for their intended use in kitchen exhaust duct systems. The installation shall be compatible with the exhaust duct and should be installed in accordance with the manufacturer's recommendations conforming to NFPA 96 guidelines and all applicable local codes.

ACCESS DOOR DETAILS

Grease Duct access doors are provided in accordance with NBCC, IMC, IBC and NFPA 96 requirements. VaughanAir Grease Duct Access doors are provided to allow for complete access and inspection as an access port. VaughanAir Grease Duct Access doors are pre-installed, eliminating the need for coordinating site fabricated/installed access doors. The inner duct access door is the industry’s only single skin and tool-less design, and the outer wall protection is a single panel design ensuring that after duct cleaning, the door is easily replaced in accordance with the listed design.

All access panels are clearly marked with wording as follows: “ACCESS PANEL - DO NOT OBSTRUCT.” Access panels are provided on horizontal duct at every change in direction and at 12ft intervals when a personal entry access cannot be provided. Access doors are provided on vertical duct, when a personal entry access cannot be provided, at each floor for cleaning. Exhaust fans with ductwork connected to both sides shall have access for cleaning and inspection within 3ft (0.92 m) of each side of the fan.

VAUGHANAIR ZERO CLEARANCE ACCESS DOORS FEATURES:

• UL 1978/E2336 Listed Access Door	• Specialized pre-applied gasketing
• No frame to re-install/re-seal after cleaning	• No welding required
• Door is completely removable for cleaning	• Eliminates misalignment issues upon re-install

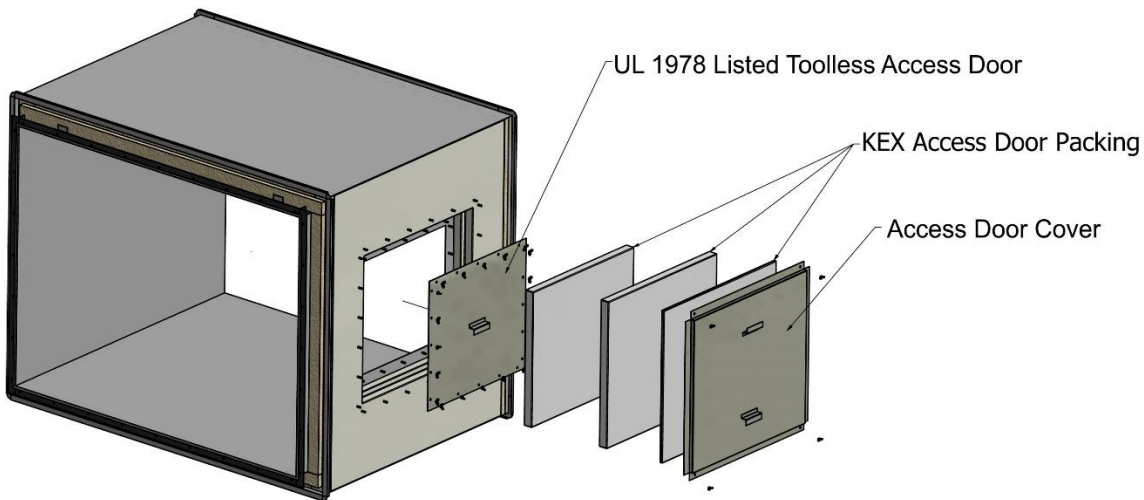

SUPPORT METHODS AND DETAILS

HORIZONTAL SUPPORTS:

The horizontal supports will provide for joint alignment and support for grease duct horizontal applications. Spacing as noted in the chart is required. The horizontal supports shall be secured to fire resistance rated structural members of the building, which can adequately support the weight of the duct system. The duct cradles are based on support rods being a maximum of 1" from the side of the duct. Consult VaughanAir if the support rods are to be installed further from the duct than noted prior to installation. Consult with local building code authorities to address the inclusion of slope in horizontal runs of grease duct.

Perimeter of Duct (Inside Dimension)	Max Duct Width (Inside Dimension)	Rod Diameter	Duct Cradle Size	Embedment Depth	Cradle Spacing
Up to 48"	12"	3/8"	2" x 2" x 1/4"	1-5/8"	59" o.c.
Up to 72"	24"	1/2"	2" x 2" x 3/8"	2-1/4"	59" o.c.
Up to 108"	36"	5/8"	2-1/2" x 2-1/2" x 3/8"	2-3/4"	59" o.c.
Up to 144"	48"	5/8"	3" x 3" x 3/8"	2-3/4"	59" o.c.
Up to 212"	60"	3/4"	3-1/2" x 3-1/2" x 1/2"	3-1/4"	59" o.c.

Notes:

- 1) Vertical rods are based on 36 ksi (250MPa) yield strength.
- 2) Vertical rod location shall be maximum 1" from the outer side wall of the duct.
- 3) Duct cradles are based on 44 ksi (300MPa) yield strength.
- 4) Duct cradle length shall extend minimum 1" beyond outer edge of threaded rod.
- 5) Anchors to be drop-in or wedge type anchors installed with minimum embedments shown above.
- 6) Please contact VaughanAir if duct supports are to deviate from the guidelines listed above for review prior to installation.
- 7) All duct supports are contractor supplied.

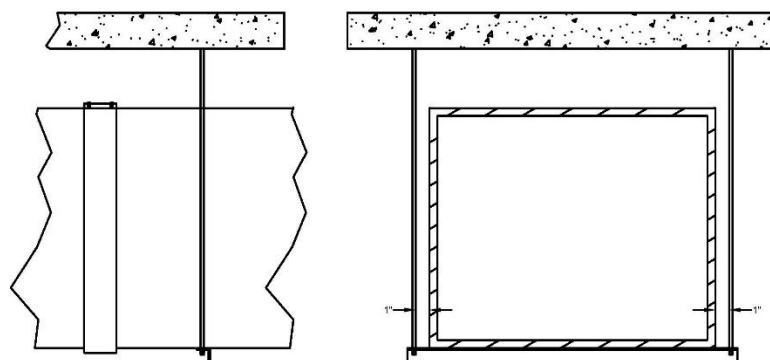

Cradle/Rod Location Detail

SLOPE REQUIREMENTS:

Consult with local building code authorities to address the inclusion of slope in horizontal runs of grease duct. Install at a slope not less than one-fourth unit vertical in 12 units horizontal toward the hood or toward a grease reservoir. Where horizontal ducts exceed 75' in length, the slope shall be not less than one unit vertical in 12 units horizontal. Contact VaughanAir for reduced slope solutions for horizontal ducts where 2% or 8% slopes are not possible.

VERTICAL SUPPORTS:

Knee Brackets - The knee brackets should maintain a 30° angle, if this is impractical consult with VaughanAir Barriers Inc. prior to installation. The vertical supports shall be secured to fire resistance rated structural members of the building, which can adequately support the weight of the duct system.

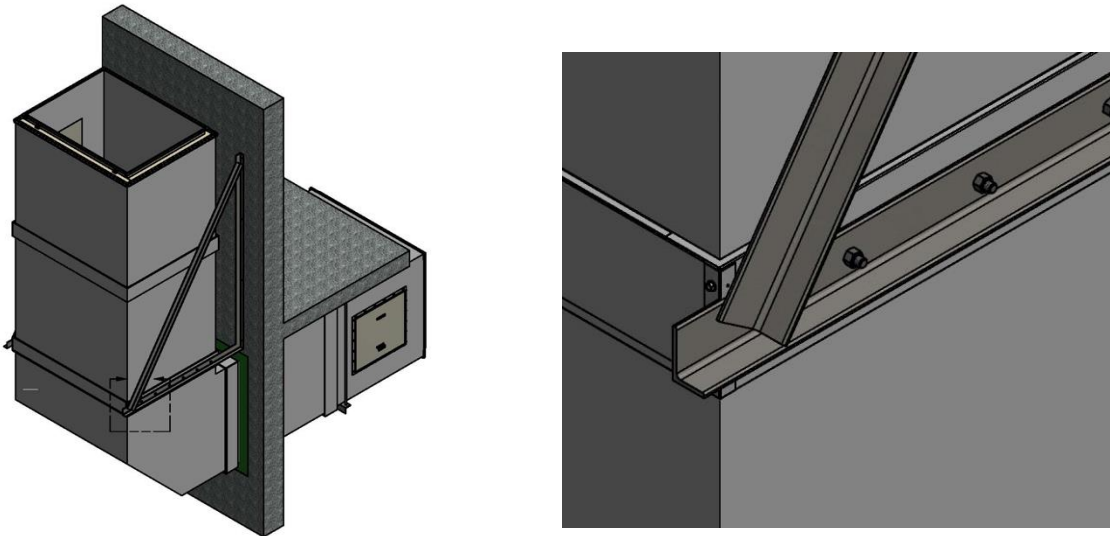

Typical Knee Bracket – Vertical Support

Perimeter of Duct	Minimum Duct Depth	Support Limit
Up to 48"	10"	30 ft
Up to 72"	12"	
Up to 108"	18"	
Up to 144"	24"	
Up to 212"	36"	
Standard Knee Bracket Angle Size	3" x 2" x 1/4"	

Notes:

- 1) Contact VaughanAir for assistance with anchor size, quantity and embedment depth.
- 2) All duct supports are contractor supplied.

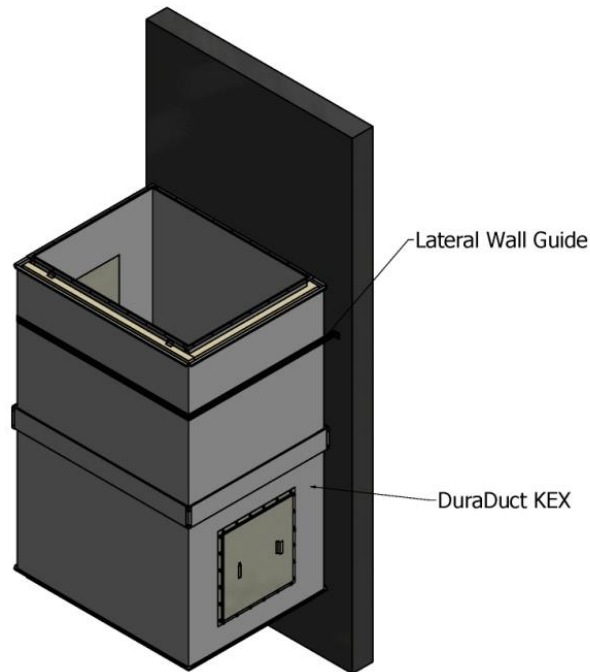

Lateral Wall Guide Detail

LATERAL GUIDE SUPPORTS

Lateral guide supports are installed every 20ft to ensure alignment during vertical installation of the DuraDuct KEX. The vertical guide supports shall be secured to fire resistance rated structural members of the building, which can adequately support the duct system. Contact VaughanAir for design assistance with the vertical guide supports.

Notes:

- 1) Please contact VaughanAir if duct supports are to deviate from the guidelines listed above for review prior to installation.
- 2) All duct supports are contractor supplied.

FLOOR SUPPORTS

Floor support channels must overlap the edge of the opening by a minimum of 3" (75mm). The floor support channel should be shimmed (steel shims) as necessary to ensure that the channel is supporting the load of the duct. The floor supports shall sit on a structural slab or member of the building, which can adequately support the weight of the grease duct system.

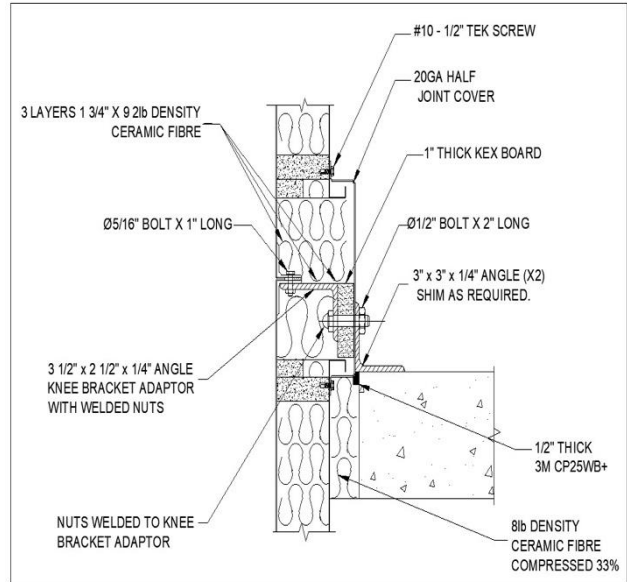
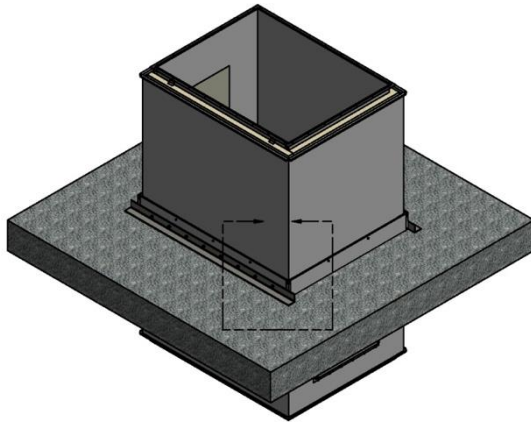

Typical Floor Support – Vertical Support

Perimeter of Duct	Minimum Duct Depth	Support Limit
Up to 48"	10"	30 ft
Up to 72"	12"	
Up to 108"	18"	
Up to 144"	24"	
Up to 212"	36"	
Standard Floor Support Angle Size		3" x 3" x 1/4"

Notes:

- 1) Please contact VaughanAir if duct supports are to deviate from the guidelines listed above for review prior to installation.
- 2) All duct supports are contractor supplied.

THROUGH-PENETRATION FIRESTOP SYSTEM

THE FIRE STOPPING IS AN INTEGRAL PART OF OUR DUCT LISTINGS AND THE FOLLOWING MUST BE FOLLOWED. ALL PENETRATIONS THRU FIRE RATED WALLS AND FLOORS MUST BE FIRE STOPPED AS SHOWN.

- 1) The annular space between the duct and the structure shall be completely filled with 8lb/ft³ (128kg/m³) Ceramic batt insulation leaving a 1/2" (12mm) gap back from the slab face. 33% compression is required to fill the annular space.
- 2) Fill the 1/2" (12mm) recess at the top of the packing material with type 3M CP25WB+ flush to the slab face. No overlap onto the supporting construction is required.
- 3) Complete the joint protection in accordance with the floor support instructions.

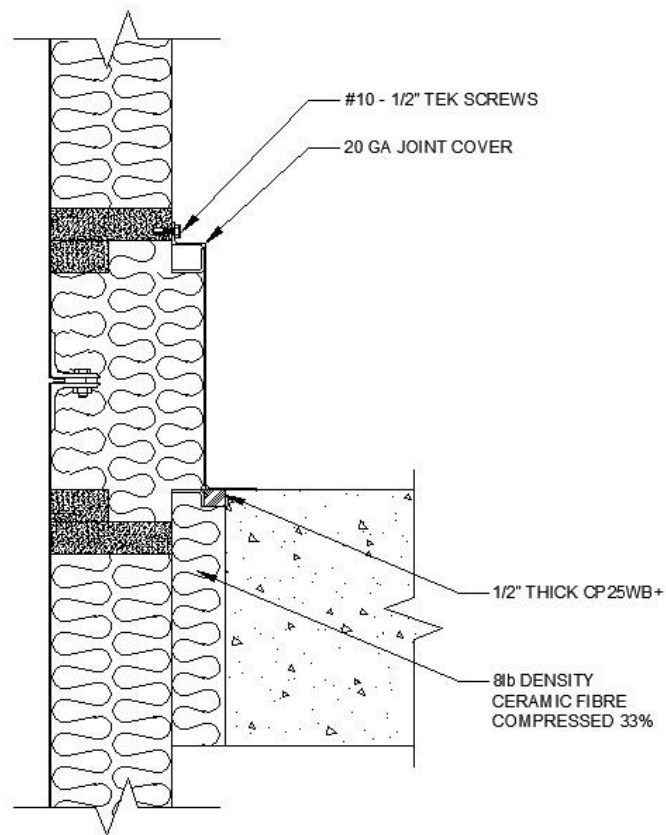

Typical Firestop Detail at Slab

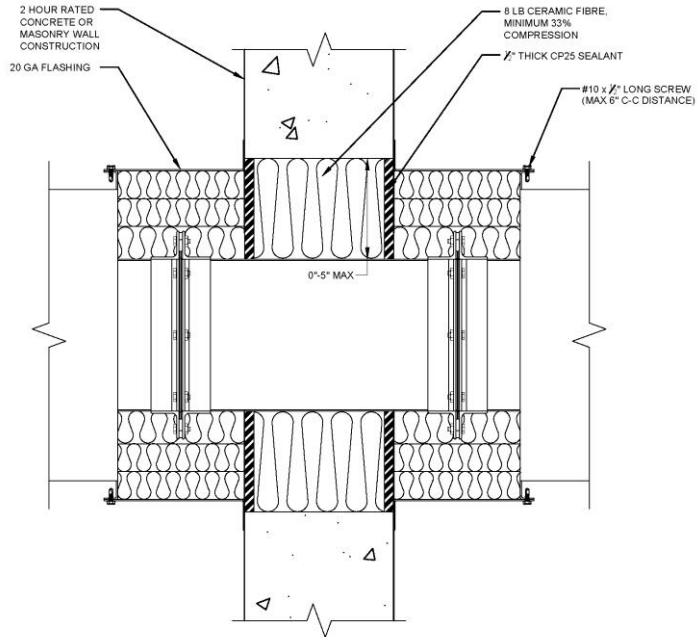

Typical Firestop Detail through a Concrete or Masonry Wall

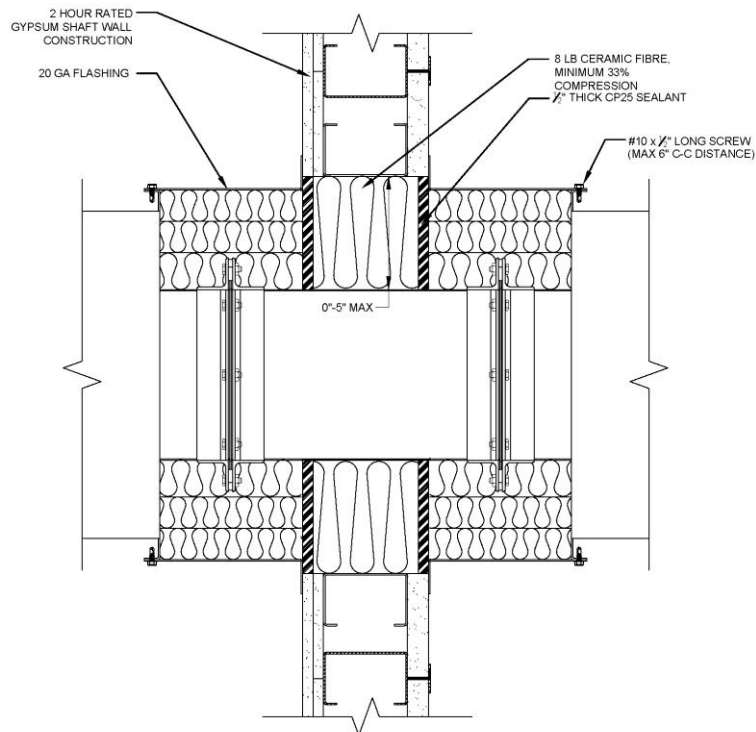

Typical Firestop Detail through a Shaft Wall

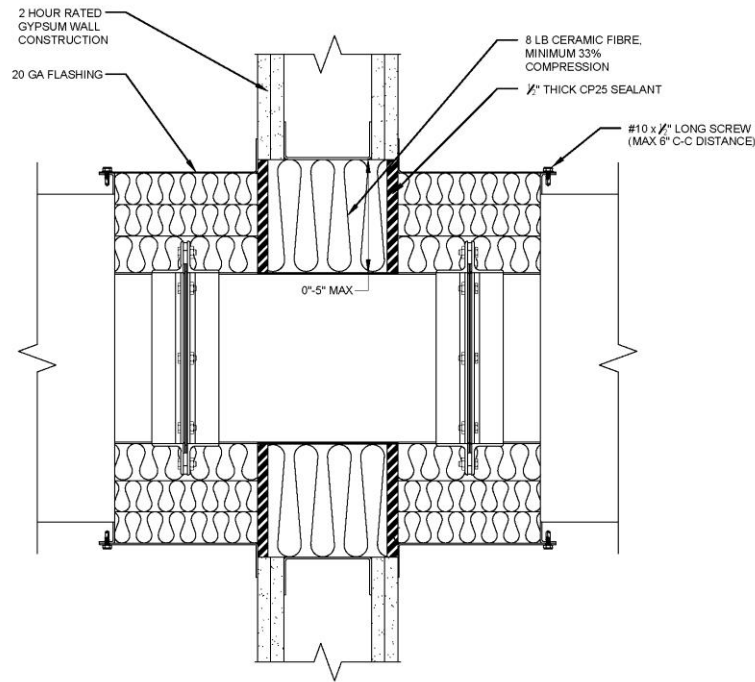

Typical Firestop Detail through a Gypsum Wall with Steel Studs

TERMINATIONS

To support a quick and easy installation, DuraDuct Model KEX, includes for special termination components as a complete system offering. The Model KEX system may terminate vertically or horizontally through the roof of the building or on an exterior wall as determined by the specified fan exhaust system. Reference your local code requirements and NFPA 96 for details.

FAN CONNECTIONS/HOOD ADAPTORS

The DuraDuct KEX design incorporates special adaptors when required to attach to all types of exhaust systems and provide a fast and easy installation. An assortment of exhaust equipment exists on the market for commercial cooking applications and should be listed in accordance with NFPA 96 to exhaust grease-laden vapors and fumes. Typical applications for fan connections and hood adaptors to follow.

HOOD CONNECTIONS:

In accordance with NFPA 96, ducts connecting to the hood canopy can be connected with a continuous weld, or refer to detail, for a non-welded connection.

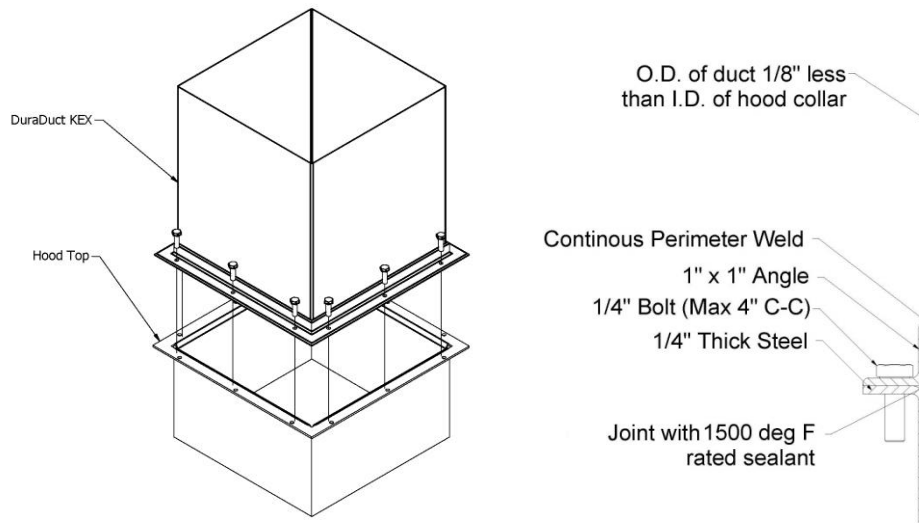

Non-Weld Hood Connection Detail A

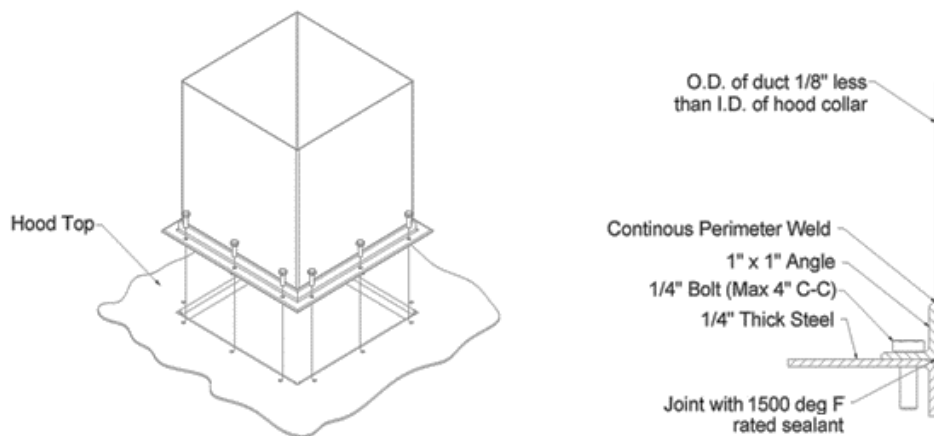

Non-Weld Hood Connection Detail B

Note: Please refer to local building code requirements to ensure bolted hood connections are acceptable in the respective jurisdiction.

ROOF PENETRATIONS

ROOF PENETRATION THROUGH CURB:

Roof curb penetration should be provided in accordance with local codes and NFPA 96 requirements where applicable. The roof curb penetration is provided with a flashing to cap the curb to the DuraDuct kitchen exhaust.

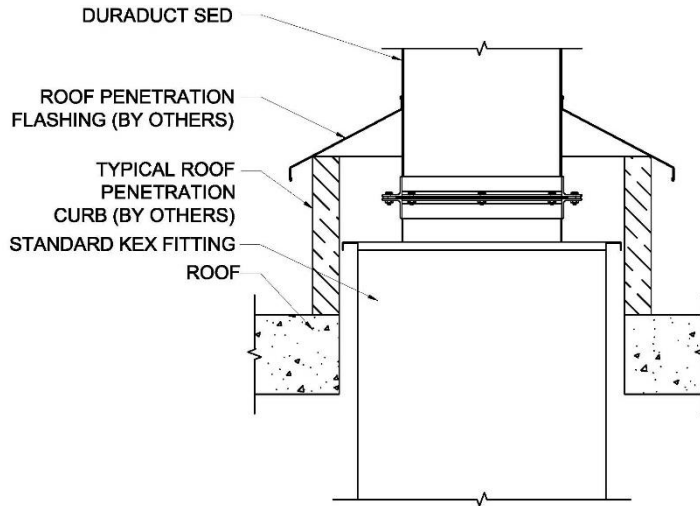

Typical Roof Penetration Detail

FIRE PROTECTION & MAINTENANCE

DUCT TESTING:

DuraDuct KEX should be tested per the project specified test method(s). Where the project specifications do not define a test method, VaughanAir recommends using one of the test methods defined in ASHRAE 154, *Ventilation for Commercial Cooking Operations*. The contractor should consult the project engineer and AHJ before selecting a test method to ensure the method is acceptable to all parties.

SPRINKLER HEAD ACCESS PORT DETAIL FOR FIRE EXTINGUISHING SYSTEMS:

Sprinkler head access ports can be provided in accordance with local codes and NFPA 96 requirements where fire-extinguishing equipment is provided for the protection of duct systems, grease removal devices and hoods. Each component comes standard with a pre-installed 1" NPT nipple to allow for easy connections.

DRAIN SECTION DETAIL:

Drain section adaptors are intended for use as a drain for all low points and at the base of a duct riser. The drain nipple must be attached to a grease trap or approved container (supplied by others). Each component comes standard with a pre-installed, minimum, 1-1/2" NPT nipple to allow for easy connections.

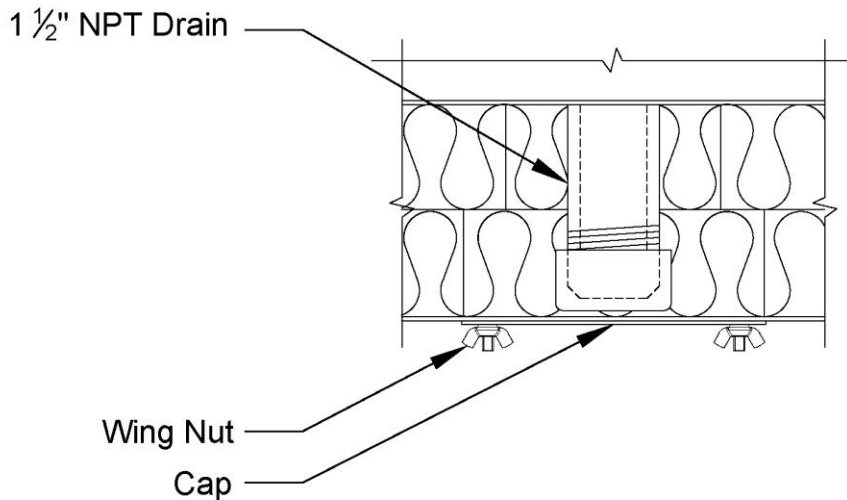

Drain Section Detail

Note: When connecting to the internal drain nipple, all piping, grease traps or approved containers must be installed in compliance with local codes and standards.

MAINTENANCE GUIDELINES:

NFPA 96 in conjunction with local building codes should be referenced for inspection and cleaning requirements. The table in the cleaning procedure outlines NFPA 96 recommended inspection for grease buildup. It is recommended that grease containers and drain ports are inspected and emptied on an ongoing basis to reduce buildup. All drain caps must be removed, and the drains connected to approved collection vessels, prior to the commencement of the duct cleaning to prevent the accumulation of grease and cleaning fluids at low points in the duct. All drain caps that were removed must be reinstalled once the duct cleaning is completed, and prior to the exhaust system being put back into service.

CLEANING PROCEDURE:

NFPA 96 recommends the entire exhaust system shall be inspected for grease buildup by a properly trained, qualified, and certified person(s) acceptable to the AHJ and in accordance with Table 11.4:

Type or Volume of Cooking	Inspection Frequency
Systems serving solid fuel cooking operations	Monthly
Systems serving high-volume cooking operations, such as 24-hour cooking, charbroiling, or wok cooking	Quarterly
Systems serving moderate-volume cooking operations	Semi-Annually
Systems serving low-volume cooking operations, such as churches, day camps, seasonal businesses, or senior centers	Annually

Table 11.4 - Schedule of Inspection for Grease Buildup (NFPA 96-17)

ACCESS DOOR REMOVAL/REPLACEMENT INSTRUCTIONS:

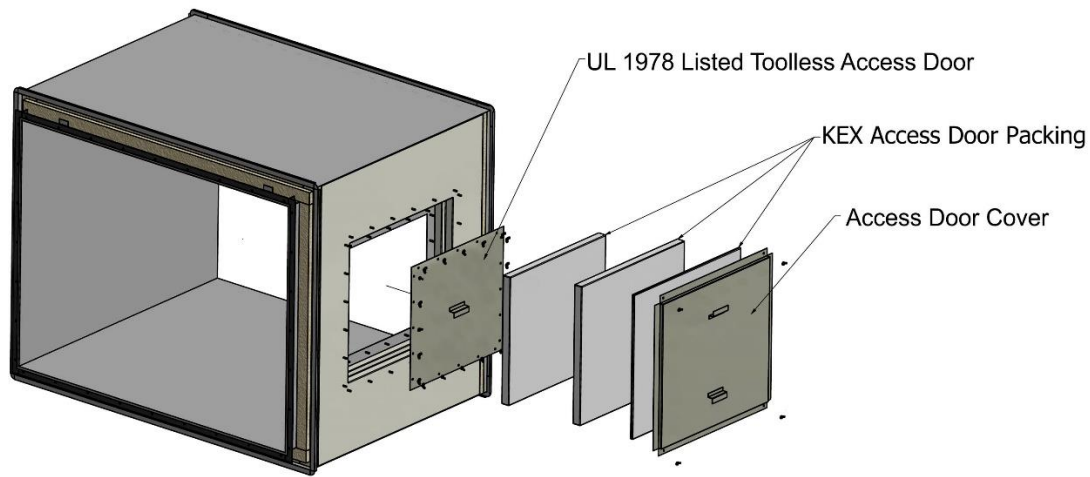

Access Door Detail

Access Door Removal instructions as follows:

- 1) Remove screws for access door cover.
- 2) Remove insulation.
- 3) Remove inner access door wing screws.
- 4) To replace, repeat these steps in reverse and finger tighten each wing screw fastener until snug.

TEST PORT DETAIL:

When requested, optional test ports doors can be supplied. Test ports can be temporarily installed where access doors openings are located, intended for use for balancing when required. The test port diameter can be built to suit site requirements. To use, follow instructions access door removal instruction above for removal of the listed access door and install the test port. When testing is complete, remove the test port and replace with the listed access door.

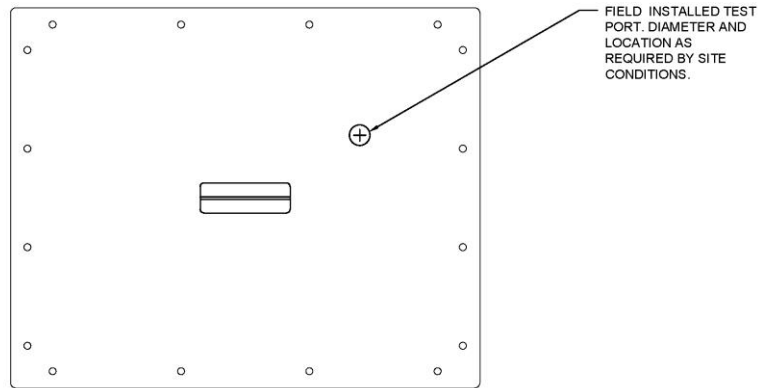

Test Port Detail

WARRANTY

These products have a limited lifetime warranty. DuraDuct KEX is not waterproof construction and must be made watertight, by others, when installed outdoors. All components must be protected from exposure to weather both prior to installation and as an installed system. Damage to your DuraDuct KEX that results from accidents such as fire, flood, high winds, “acts of God”, or any other contingency beyond our control is not covered. Please contact VaughanAir or your local representative for further information.



Pennsylvania Avenue ■ Concord, ON L4K 4A6, Canada
TEL: 647.946.4770 ■ EMAIL: sales@vaughanair.com