

# Installation Instructions and Operation & Maintenance Manual

## DuraDuct SED

Single Wall Kitchen Exhaust System  
Listed to UL 1978 & CAN/ULC-S662

**Do not install this grease duct system without completely reading the installation instructions. All details as noted in this document must be followed. For further information please contact VaughanAir.**

199 Courtland Avenue ■ Concord, ON L4K 4T2, Canada  
TEL: 647.946.4770 ■ EMAIL: [sales@vaughanair.com](mailto:sales@vaughanair.com)

## CONTENTS

|   |           |
|---|-----------|
| <b>GENERAL INFORMATION</b> .....  | <b>2</b>  |
| Product Features: .....   | 2         |
| Design Listing Information: .....                                       | 3         |
| <b>CONSTRUCTION DETAILS</b> .....                                       | <b>3</b>  |
| Duct Construction Materials: .....                                      | 8         |
| Code Compliance: .....  | 9         |
| Handling & Storage Instructions: .....                                  | 9         |
| Connection Details: .....   | 9         |
| Flange Assembly Instructions: .....                                     | 10        |
| Common Duct (Manifold) Systems: .....                                   | 11        |
| Dampers: .....  | 11        |
| <b>ACCESS PANEL DETAILS</b> .....                                       | <b>11</b> |
| VaughanAir Access Panel Features: .....                                 | 12        |
| <b>SUPPORT METHODS AND DETAILS</b> .....                                | <b>12</b> |
| Horizontal Supports: .....  | 12        |
| Slope Requirements: .....   | 14        |
| Vertical Supports: .....  | 15        |
| Lateral Guides: .....   | 16        |
| Floor Supports: .....   | 17        |
| <b>TERMINATIONS</b> .....   | <b>18</b> |
| Hood Connections: .....   | 18        |
| <b>LEAK TESTING</b> .....   | <b>19</b> |
| <b>FIRE PROTECTION &amp; MAINTENANCE</b> .....                          | <b>19</b> |
| Sprinkler Head Access Port detail for fire extinguishing systems: ..... | 19        |
| Drain Section Detail: .....   | 19        |
| Test Port Detail: .....   | 20        |
| Maintenance Guidelines: .....   | 20        |
| Cleaning Procedure: .....   | 20        |

## GENERAL INFORMATION

DuraDuct SED is a segmented, pre-manufactured and non-combustible single wall grease duct system. DuraDuct SED is an 18" clearance system to all combustible materials. Clearance reduction systems may be applied in accordance with NFPA 96.4.3.2. By using a flange-to-flange connection, the system will eliminate the need for field welding of code compliant grease duct systems and provide a rectangular footprint to allow flexibility in the design of the exhaust ductwork in Type I and Type II grease duct systems.

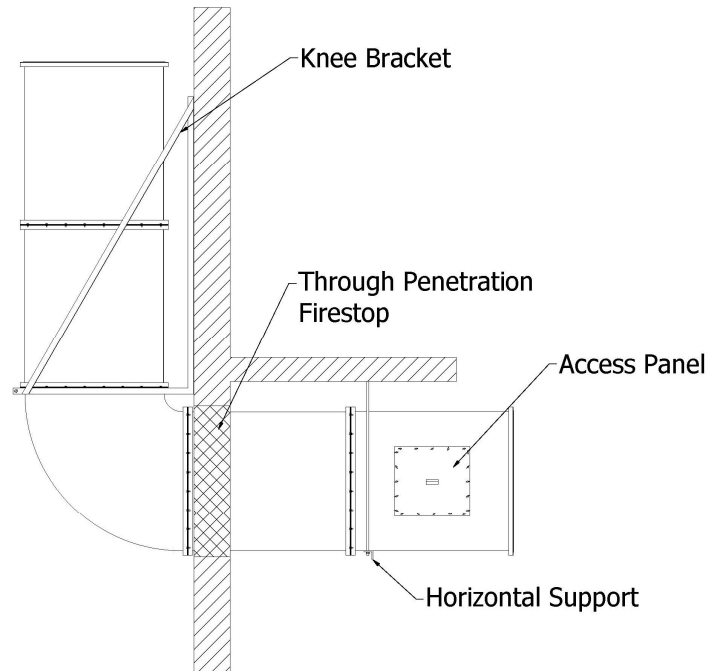

**General Layout Detail**

### PRODUCT FEATURES:

- UL 1978 & CAN/ULC-S662 listed
- Rectangular, space saving footprint
- No weld system; flange-to-flange connections
- Built-in, UL 1978 & CAN/ULC-S662 listed and NFPA 96 complaint toolless grease duct access doors
- Reduced clearance options in accordance with NFPA 96 4.2.3
- Code prescribed duct materials
- Specialized fittings available
- Factory tested seam welds

## DESIGN LISTING INFORMATION:

DuraDuct SED is listed in accordance with UL 1978 & CAN/ULC-S662 by Intertek.

Listing number VAC/FMF 30-01.

## CONSTRUCTION DETAILS

DuraDuct SED is constructed with code prescribed, fully welded, duct materials. It is supplied with UL 1978 & CAN/ULC-S662 tested and listed flange-to-flange connections. Standard lengths are 59" long and specialized fittings are available to suit the system design.

### Materials:

- Liner: 16ga C.R. Steel – Standard
- 18ga 304 Stainless Steel – Premium
- 18ga 316 Stainless Steel – Premium

### Angle Flanges:

- 1-1/2" x 1/8" Hot Rolled Steel Structural Angle – Standard
- 1-1/2" x 1/8" 304 Stainless Steel Structural Angle – Premium
- 1-1/2" x 1/8" 316 Stainless Steel Structural Angle – Premium

### Duct Weight:

- 3.1 lbs/sq. ft.

### Standard Fittings:

- See the attached pages for DuraDuct SED standard fittings and dimensions.
- Minimum standard internal duct size is 12" x 12". Contact VaughanAir if smaller duct sizes are required.
- Non-Standard fittings, fittings sizes, and fitting configurations are available for a premium. Contact VaughanAir for details.

### Construction:

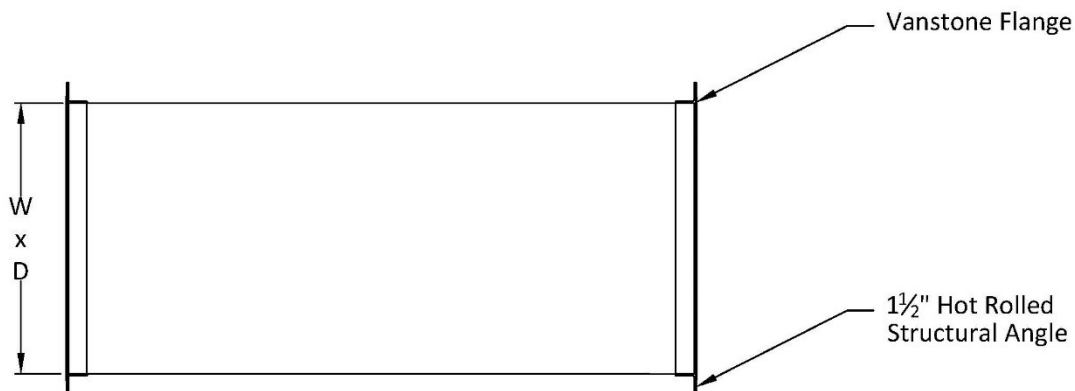

DuraDuct SED Construction Detail

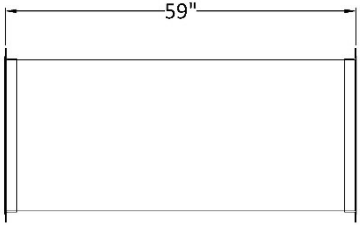
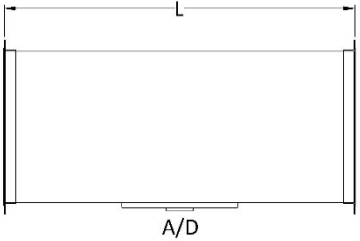
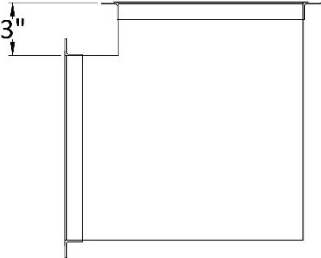
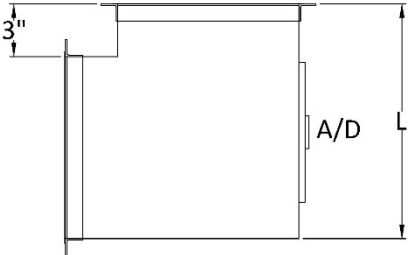
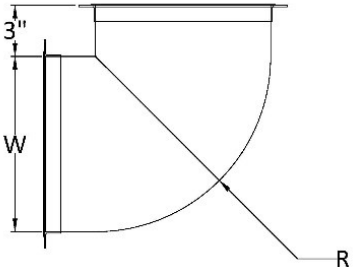
|   |  |
|---|--|
|    | <p><b><u>Straight Duct</u></b></p> <p>Standard Length = 59"<br/>         Minimum Length = 12"<br/>         ** Duct lengths shorter than 12" should be added to adjacent fitting.</p> |
|    | <p><b><u>Straight With Access Door</u></b></p> <p>Minimum Length with access door (L) = 18"</p>  |
|   | <p><b><u>90° Square Elbow</u></b></p> <p>Standard Throat = 3"</p>  |
|  | <p><b><u>90° Square Elbow with Access Door</u></b></p> <p>Standard Throat = 3"<br/>         Minimum Heel Length (L) = 18"</p>  |
|  | <p><b><u>90° Radius Elbow</u></b></p> <p>Standard Throat = 3"<br/>         Standard Radius (R) = W</p>   |

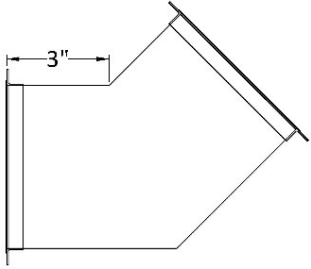
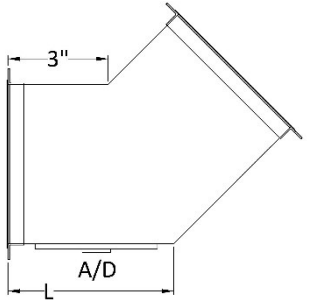
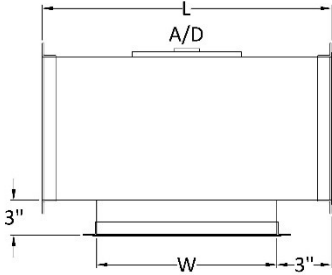
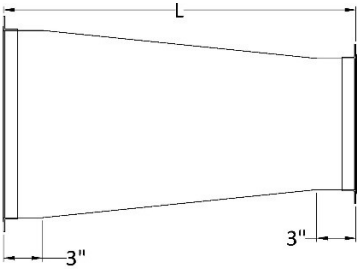
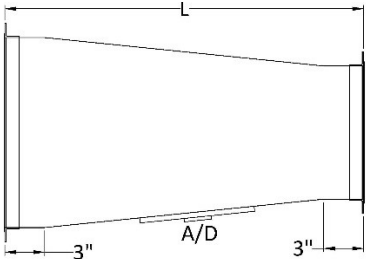
|   |   |
|---|---|
|    | <p><b><u>45° Elbow</u></b></p> <p>Standard Throat = 3"</p>  |
|    | <p><b><u>45° Elbow with Access Door</u></b></p> <p>Standard Throat = 3"<br/>Minimum heel length for access door (L) = 18"</p>                 |
|   | <p><b><u>Straight Duct with Tap</u></b></p> <p>Standard Throat = 3"<br/>Length (L) = W + 6"<br/>Minimum length with access door (L) = 20"</p> |
|  | <p><b><u>Transition</u></b></p> <p>Standard length (L) = 24"</p>  |
|  | <p><b><u>Transition With Access Door</u></b></p> <p>Standard length with access door (L) = 24"</p>  |

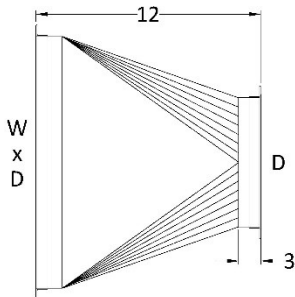
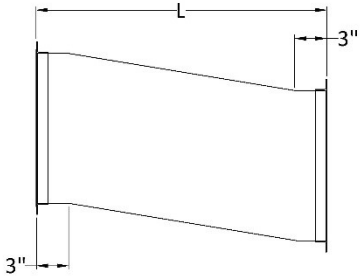
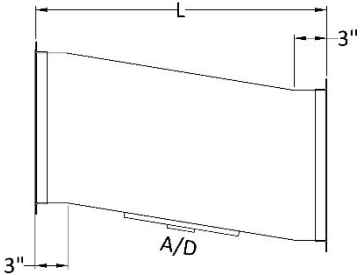
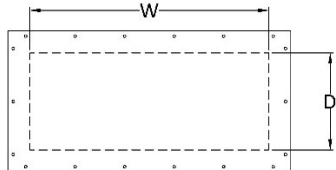
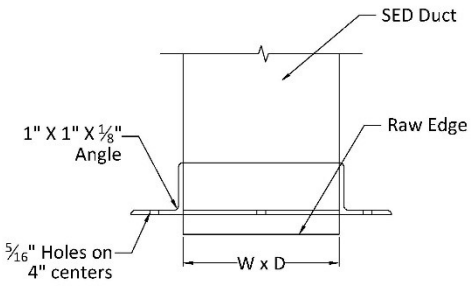
|   |  |
|---|--|
|    | <p><b>Square to Round</b></p> <p>Standard Length = 12"<br/> <math>W \times D</math> = Rectangular Duct<br/> <math>D</math> = Diameter of Round Duct</p> <p>Access door not available</p> |
|    | <p><b>Offset</b></p> <p>Standard Length (L) = 24"</p>  |
|   | <p><b>Offset With Access Door</b></p> <p>Standard Length with access door (L) = 24"</p>  |
|  | <p><b>Block End</b></p> <p><math>W \times D</math> = Nominal Duct Dimensions</p>   |
|  | <p><b>Bolted Hood Connection</b></p> <p><math>W \times D</math> = (I.D of hood flange) - (1/16")</p>   |

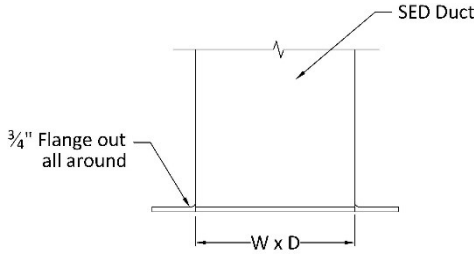
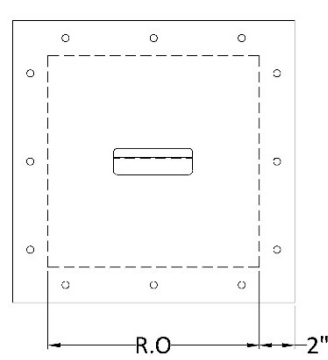
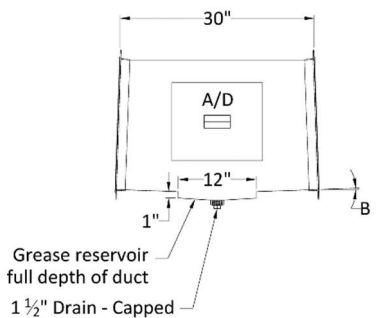
|   |  |           |           |          |          |          |          |           |  |  |
|---|--|-----------|-----------|----------|----------|----------|----------|-----------|--|--|
|  <p>SED Duct</p> <p>3/4" Flange out all around</p> <p>W x D</p>  | <p><b><u>Welded Hood Connection</u></b></p> <p>W x D = I.D. of hood flange<br/>SED flange to be field welded of hood flange</p>  |           |           |          |          |          |          |           |  |  |
|  <p>R.O. 2"</p>   | <p><b><u>Access Doors</u></b></p> <p>Access doors are located per IMC or NFPA code requirements.</p> <p>International Mechanical Code (IMC):<br/>A 20"x20" man size access door shall be installed if duct size permits.</p> <p>or</p> <p>12" x 12" access doors shall be installed not more than 20' apart and not more than 10' from changes in direction greater than 45 degrees.</p> <p>National Fire Protection Association (NFPA):<br/>A 20"x20" man size access door shall be installed if duct size permits.</p> <p>or</p> <p>Access doors shall be installed at 12' intervals and at every change of direction.</p> <p>Standard Door Opening Sizes (R.O.)</p> <table border="0"> <tr> <td>12" x 12"</td> <td>12" x 10"</td> <td>12" x 8"</td> </tr> <tr> <td>12" x 6"</td> <td>12" x 4"</td> <td>12" x 2"</td> </tr> <tr> <td>20" x 20"</td> <td></td> <td></td> </tr> </table> | 12" x 12" | 12" x 10" | 12" x 8" | 12" x 6" | 12" x 4" | 12" x 2" | 20" x 20" |  |  |
| 12" x 12"   | 12" x 10"  | 12" x 8"  |           |          |          |          |          |           |  |  |
| 12" x 6"  | 12" x 4"   | 12" x 2"  |           |          |          |          |          |           |  |  |
| 20" x 20"   |  |           |           |          |          |          |          |           |  |  |
|  <p>30"</p> <p>A/D</p> <p>12"</p> <p>1"</p> <p>B</p> <p>Grease reservoir full depth of duct</p> <p>1 1/2" Drain - Capped</p> | <p><b><u>Grease Reservoir</u></b></p> <p>Standard length = 30"<br/>Slope (B) = 1% for duct run ≤ 75'<br/>= 4% for duct run over 75'</p>  |           |           |          |          |          |          |           |  |  |

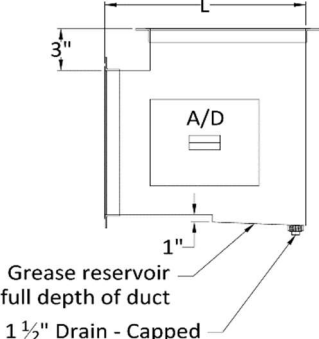
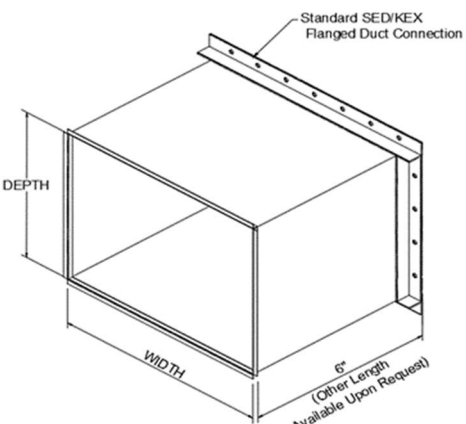
|   |   |
|---|---|
|  <p>3"<br/>L<br/>A/D<br/>1"<br/>Grease reservoir<br/>full depth of duct<br/>1 1/2" Drain - Capped</p>                          | <p><b><u>90° Square Elbow with Grease Reservoir</u></b></p> <p>Standard Throat = 3"<br/>Minimum Heel Length (L) = 18"</p>   |
|  <p>Standard SED/KEX<br/>Flanged Duct Connection<br/>DEPTH<br/>WIDTH<br/>6"<br/>(Other Length<br/>Available Upon Request)</p> | <p><b><u>Welded Duct to SED Adapter Fitting</u></b></p> <p>Standard Length = 6"</p> <p>1/2" to 1" Flange supplied to connect to<br/>existing welded duct flange</p> |

## DUCT CONSTRUCTION MATERIALS:

DuraDuct SED is manufactured in either minimum 16 gauge steel or minimum 18 gauge stainless steel.

**Note:** In the USA follow IMC Section 506 for grease duct materials construction and contact VaughanAir or consult AHJ prior to installing system.

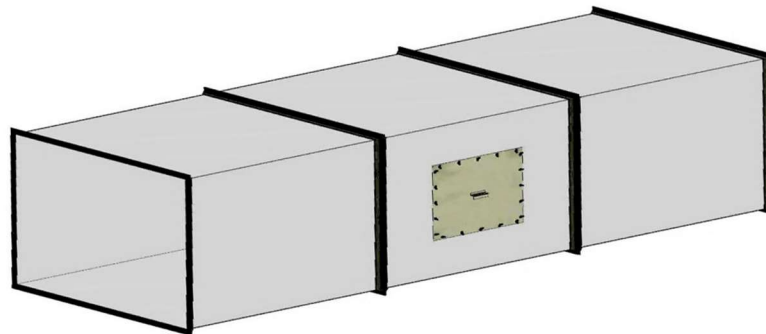

## CODE COMPLIANCE:

The DuraDuct SED system, installed as per the UL 1978 & CAN/ULC-S662 design listing, meets the requirements of the following codes: National Building Code of Canada, International Mechanical Code, International Building Code and NFPA 96.

As a UL 1978 & CAN/ULC-S662 listed assembly, DuraDuct SED can be enclosed in an ASTM E2336 enclosure system to achieve a required fire resistance rating. The final rating of the system is dependent on the rating of the specific enclosure system that is applied over the DuraDuct SED.

## HANDLING & STORAGE INSTRUCTIONS:

DuraDuct SED is a robust system, however, care should be taken in handling the ductwork. Each component should be inspected for damage upon receipt. If damage has occurred:

- 1) Notify VaughanAir and the freight company upon receipt of the goods.
- 2) Record damaged items on the bill of lading.
- 3) Send pictures of damaged items to VaughanAir.

Standard carbon steel DuraDuct SED is not corrosion resistant corrosion and minor rusting may occur if stored in unconditioned spaces for prolonged periods prior to installation. DuraDuct SED must be stored indoors, and protected from any wind driven moisture if the building is not fully enclosed. In areas with high humidity or large temperature differences over the day that could result in condensation forming, the DuraDuct sections should be stored vertically to allow any condensation to run off rather than pooling.

Slight surface rust on carbon steel duct is normal and strictly a cosmetic issue. This type of rust will not affect the functionality or longevity of the SED system once put into service.

## CONNECTION DETAILS:

All components are supplied with bolt-up type flanged connections. All flanged connections are designed alike providing a quick and trouble-free installation. All flange gasket, insulation, sealant, nuts, bolts, washers and screws are provided to complete the single-source design. Assembly details follow.

## FLANGE ASSEMBLY INSTRUCTIONS:

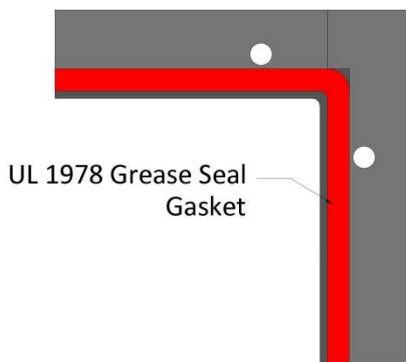
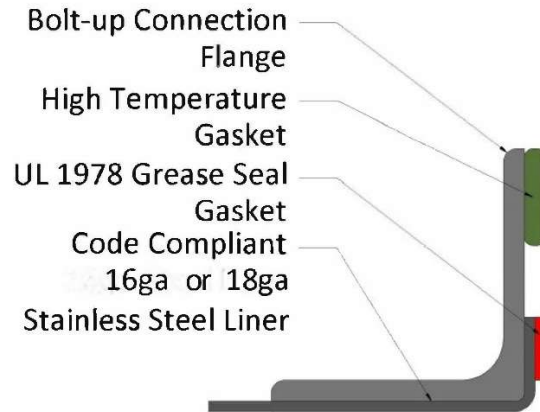

Figure 1

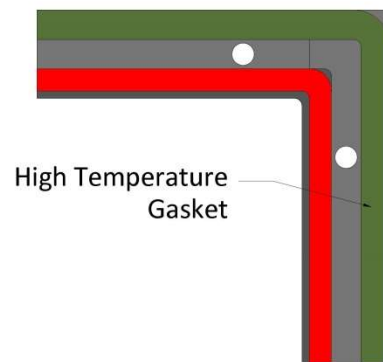
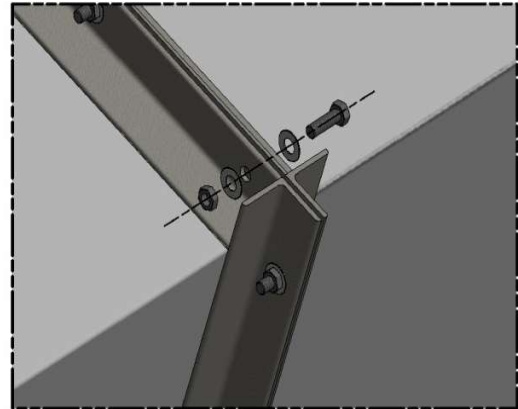
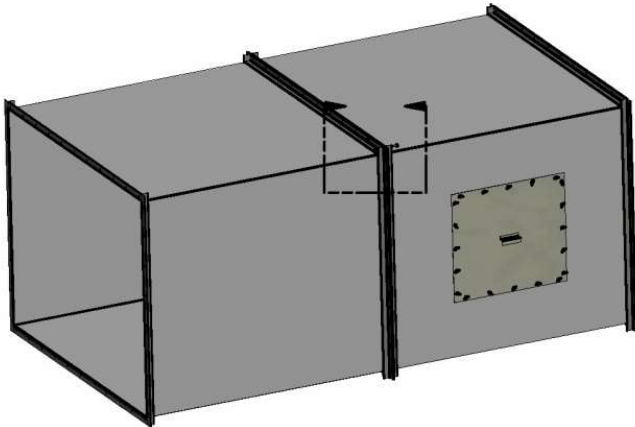

Figure 2

### Step 1:

- a) Thoroughly clean the connection flange of any oil or debris (a solvent-based degreaser may be used) to ensure a positive bond between the gasket and steel flange.
- b) Install the grease seal gasket by removing the paper backing and applying the gasket flush to the outer edge of the Vanstone flange (Figure 1). For horizontal duct configurations, any splices in the UL 1978 Grease Seal Gasket should be made at the top portion of the duct. Be sure not to stretch the gasket while applying it to the steel flange.
- c) Install the high temperature gasket by removing the paper backing, folding the gasket in half, and applying the gasket flush to the outer edge of the angle frame (Figure 2).



## Step 2:

Connect each section using the supplied 5/16" bolt assembly. A nut, bolt and two flat washers are provided for each bolt hole. Be sure to not disturb the sealant when assembling. Tighten each bolt assembly making sure to check each fastener. Bolt assembly to be torqued to 75 to 95 lbf-in.

**Tip:** A drift pin is helpful to locate the bolt holes.

## COMMON DUCT (MANIFOLD) SYSTEMS:

DuraDuct SED is capable of tying together multiple hoods in a single common duct. Make sure to follow the installation drawings closely for specific details regarding these systems.

## DAMPERS:

Dampers should be listed for their intended use in kitchen exhaust duct systems. The installation shall be compatible with the exhaust duct and should be installed in accordance with the manufacturer's recommendations conforming to NFPA 96 guidelines and all applicable local codes.

## ACCESS PANEL DETAILS

DuraDuct SED access panels are provided in accordance with NBCC, IMC, IBC and NFPA 96 requirements. The grease duct access panels are provided to allow for complete access and inspection as an access port. DuraDuct SED access panels come pre-installed, eliminating the need for cutting and installing access panels in the field. The DuraDuct SED access panel is the industry's only single skin and toolless design so after the duct cleaning is completed, the door is easily replaced in accordance with the listed design.

All access panels are clearly marked with wording as follows: "ACCESS PANEL - DO NOT OBSTRUCT." Access panels are provided on horizontal duct per NFPA 96 or IMC requirements. See fitting section for details. Access doors are provided on vertical duct, when a personal entry access cannot be provided, at each floor for cleaning. Exhaust fans with ductwork connected to both sides shall have access for cleaning and inspection within 3ft (0.92 m) of each side of the fan.

## VAUGHANAIR ACCESS PANEL FEATURES:

|   |  |
|---|--|
| UL 1978 Listed Access Panel                   | Specialized pre-applied gasketing              |
| No frame to re-install/re-seal after cleaning | No welding required                            |
| Door is completely removable for cleaning     | Eliminates misalignment issues upon re-install |

### Access Panel Removal instructions as follows:

- 1) Remove wing nuts for access door.
- 2) Remove access panel.
- 3) To replace, repeat these steps in reverse and finger tighten each wing nut until snug.

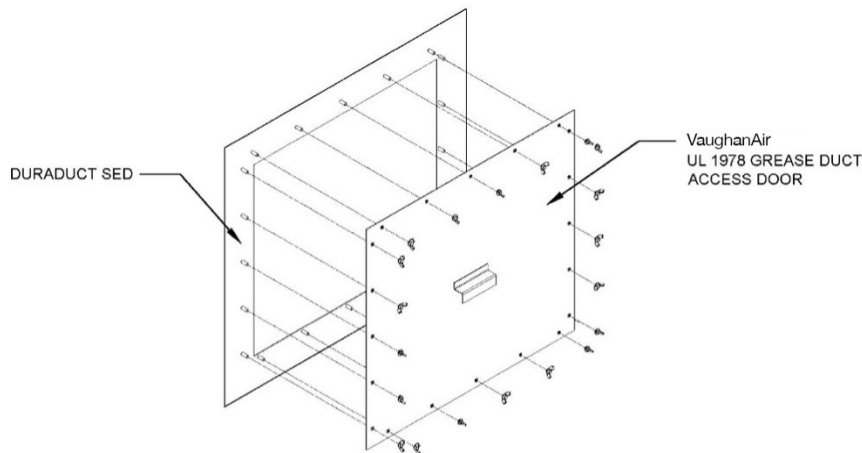

Access Panel Detail

## SUPPORT METHODS AND DETAILS

### HORIZONTAL SUPPORTS:

The horizontal supports (supplied by others) will provide for joint alignment and support for grease duct horizontal applications. The horizontal supports shall be secured to structural members of the building, which can adequately support the weight of the grease duct system. Horizontal duct supports shall be installed in accordance with the IMC, NBCC and NFPA 96 as required. Consult with VaughanAir for technical support.

| Perimeter of Duct | Max Duct Width | Rod Diameter | Embedment Depth | Duct Hanger Size        | Alternate Unistrut Cradle Size   | Hanger Spacing |
|-------------------|----------------|--------------|-----------------|-------------------------|----------------------------------|----------------|
| Up to 48"         | 12"            | 1/4"         | 1-1/8"          | 1" x 1" x 1/8"          | 1" x 1-5/8" x 1" x 12 ga         | 96" O.C.       |
| Up to 72"         | 24"            | 1/4"         | 1-1/8"          | 1" x 1" x 1/8"          | 1" x 1-5/8" x 1" x 12 ga         | 96" O.C.       |
| Up to 108"        | 36"            | 1/4"         | 1-1/8"          | 1-1/2" x 1-1/2" 1/8"    | 1-3/8" x 1-5/8" x 1-3/8" x 12 ga | 96" O.C.       |
| Up to 144"        | 48"            | 1/4"         | 1-1/8"          | 1-1/2" x 1-1/2" x 3/16" | 1-3/8" x 1-5/8" x 1-3/8" x 12 ga | 96" O.C.       |
| Up to 212"        | 60"            | 3/8"         | 1-5/8"          | 1-1/2" x 1-1/2" x 1/4"  | 1-5/8" x 1-5/8" x 1-5/8" x 12 ga | 96" O.C.       |

**Notes:**

- 1) Hanger size requirements are intended for non-fire rated installations only.
- 2) Vertical rods are based on 36 ksi (250MPa) design.
- 3) Vertical rod location shall be maximum 1" from the outer side wall of the duct.
- 4) Duct hangers are based on 36 ksi (250MPa) design.
- 5) Duct hanger length shall extend minimum 1" beyond outer edge of threaded rod.
- 6) Please contact VaughanAir if duct supports are to deviate from the guidelines listed above for review prior to installation.

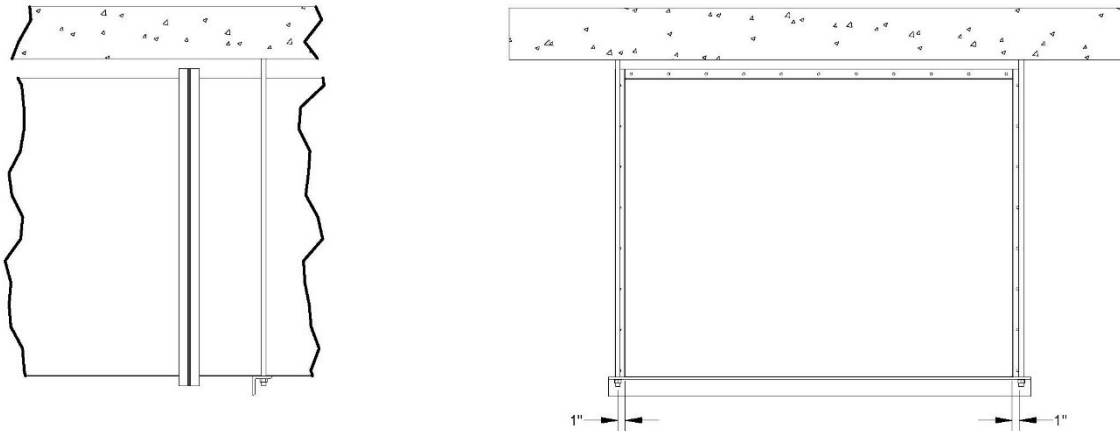

**Cradle/Rod Location Detail**

## SLOPE REQUIREMENTS:

Consult with your local building code authorities regarding slope requirements for horizontal runs of grease duct. VaughanAir grease ducts should be installed with a minimum slope of 1/8 inch vertical per 12 inches horizontal for runs up to 75 feet, and a minimum slope of 1/2 inch vertical per 12 inches horizontal for runs over 75 feet. Contact VaughanAir for alternative slope solutions if these requirements cannot be met.

| Slope                     |                                  |
|---------------------------|----------------------------------|
| Horizontal Length         | Vertical Rise Per Horizontal Run |
| Less than or equal to 75' | 1/8" per 12" (1% or 0.6°)        |
| Greater than 75'          | 1/2" per 12" (4% or 2.4°)        |

## VERTICAL SUPPORTS:

Knee Brackets - The knee brackets (supplied by others) should maintain a 45° angle. If this is impractical, consult with VaughanAir Barriers Inc. prior to installation. The vertical supports shall be secured to structural members of the building, which can adequately support the weight of the grease duct system. Vertical duct supports shall be installed in accordance with the International Mechanical Code, consult with VaughanAir for technical support.

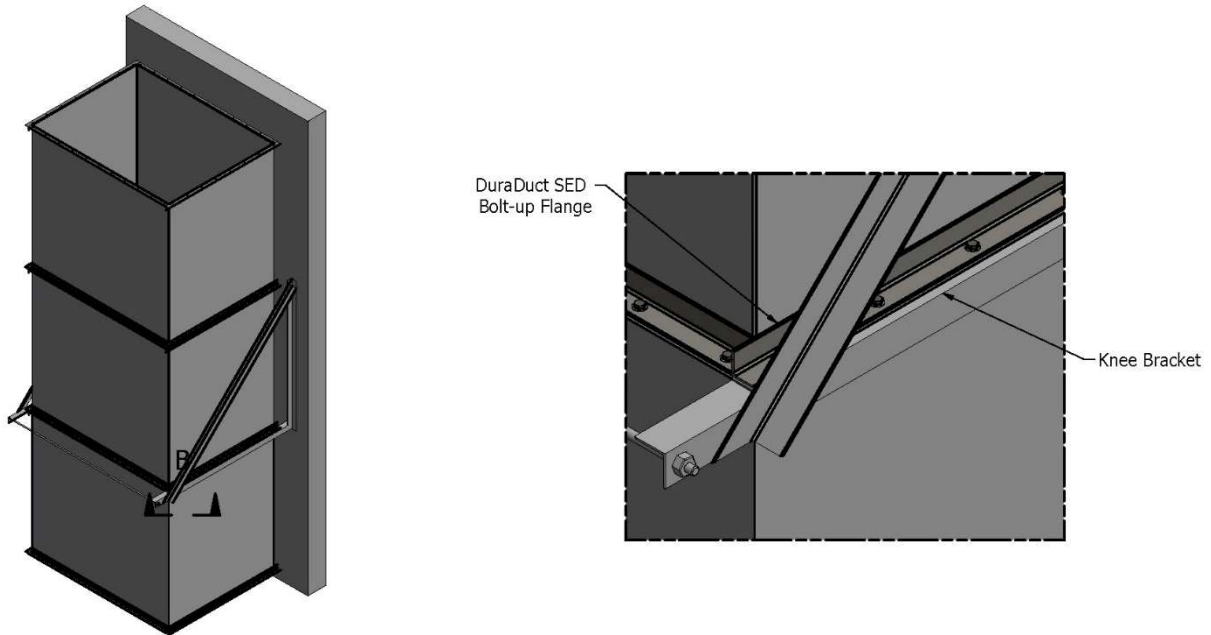

Typical Knee Bracket – Vertical Support

| Perimeter of Duct                | Minimum Duct Depth | Support Limit |
|----------------------------------|--------------------|---------------|
| Up to 48"                        | 8"                 | 50 ft         |
| Up to 72"                        | 12"                | 50 ft         |
| Up to 108"                       | 18"                | 50 ft         |
| Up to 144"                       | 24"                | 50 ft         |
| Up to 212"                       | 36"                | 50 ft         |
| Standard Knee Bracket Angle Size | 3" x 2" x 1/4"     |               |

### Notes:

- 1) Support limits are intended for non-fire rated installations only.
- 2) Please contact VaughanAir if duct supports are to deviate from the guidelines listed above for review prior to installation.

## LATERAL GUIDES:

Lateral Guides - The vertical supports will adequately support the weight of the grease duct system; however, lateral guides (supplied by others) should be used to maintain alignment during installation. Lateral guides should be placed every 20ft maximum span using an 11ga x 2" strap unless a vertical knee bracket support is already installed. Two anchors per guide should be used, refer to wall anchor sizing from the vertical support chart above. If lateral guides as shown cannot be used consult with VaughanAir for technical support.

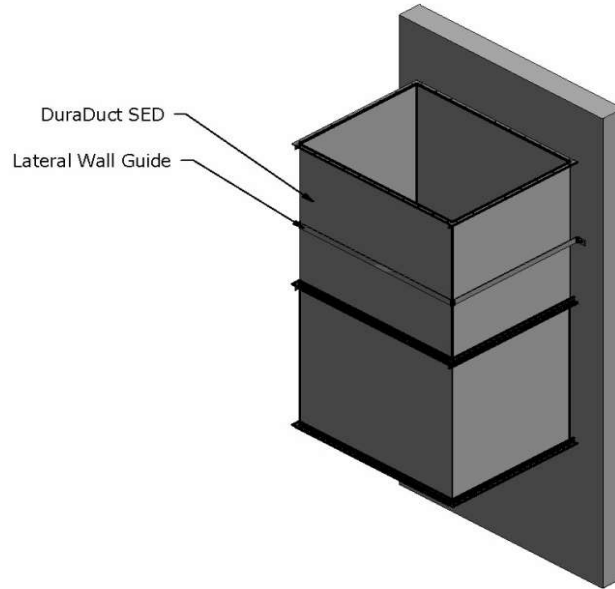

**Lateral Wall Guide**

## FLOOR SUPPORTS:

Floor support channels must overlap the edge of the opening by a minimum of 3" (75mm). The floor support channel should be shimmed (steel shims) as necessary to ensure that the channel is supporting the load of the duct. The floor supports shall sit on a structural slab or member of the building, which can adequately support the weight of the grease duct system.

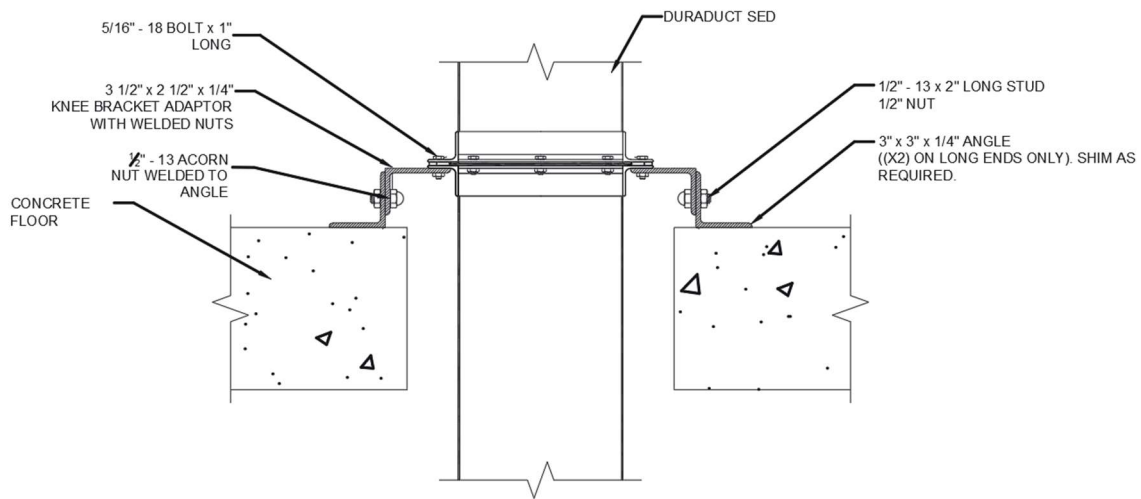
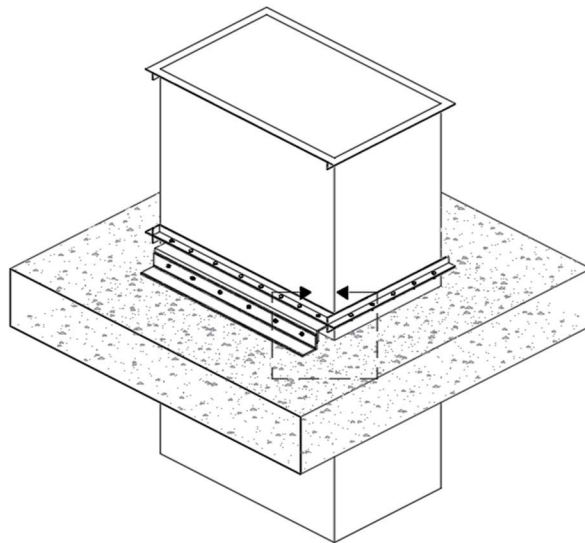

**Floor Support Detail**

**Note:** All duct supports are contractor supplied.

## TERMINATIONS

To support a quick and easy installation, DuraDuct SED includes for special termination components as a complete system offering. The DuraDuct SED system may terminate vertically or horizontally through the roof of the building or on an exterior wall as determined by the specified fan exhaust system. Reference your local code requirements and NFPA 96 for details.

### HOOD CONNECTIONS:

In accordance with NFPA 96, ducts connecting to the hood canopy can be connected with a continuous weld, or refer to detail, for a non-welded connection.

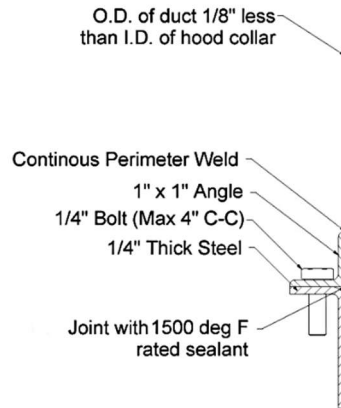
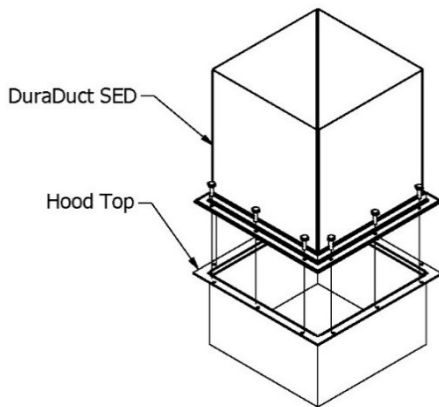

**Non-Weld Hood Connection Details**

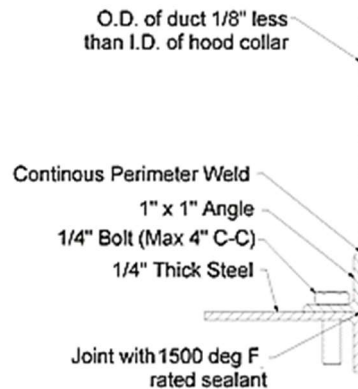
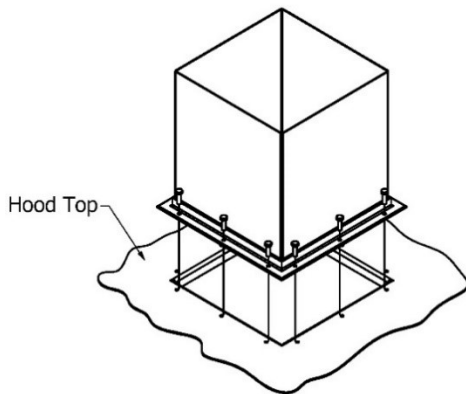

**Non-Weld Hood Connection Details**

## LEAK TESTING

VaughanAir recommends testing to ASHRAE 154 requirements when project specifications do not specify a required testing method.

## FIRE PROTECTION & MAINTENANCE

### SPRINKLER HEAD ACCESS PORT DETAIL FOR FIRE EXTINGUISHING SYSTEMS:

Sprinkler head access ports can be provided in accordance with local codes and NFPA 96 requirements where fire-extinguishing equipment is provided for the protection of duct systems, grease removal devices and hoods. Each component comes standard with a pre-installed 1" NPT nipple to allow for easy connections.

### DRAIN SECTION DETAIL:

Drain section adaptors are intended for use as a drain for all low points and at the base of a duct riser. The drain nipple must be attached to a grease trap or approved container (supplied by others). Each component comes standard with a pre-installed, minimum, 1-1/2" NPT nipple to allow for easy connections.

When connecting to the internal drain nipple, all piping, grease traps or approved containers must be installed in compliance with local codes and standards.

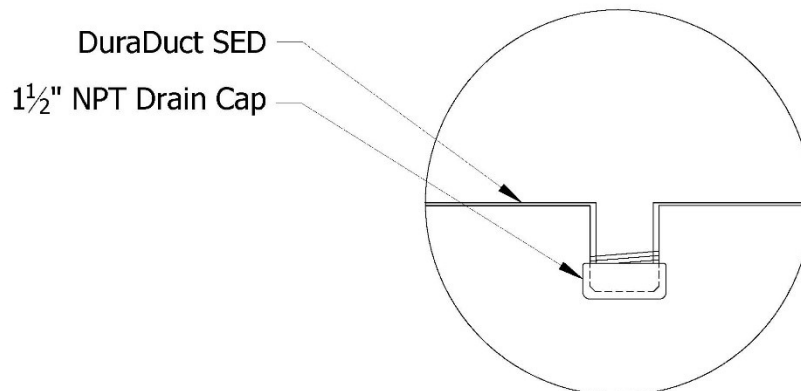

**Drain Section Detail**

## TEST PORT DETAIL:

When requested, optional test ports doors can be supplied. Test ports can be temporarily installed where access doors openings are located, intended for use for balancing when required. The test port diameter can be built to suit site requirements. To use, follow page 10 instructions for removal of the listed access door and install the test port. When testing is complete, remove the test port and replace with the listed access door.

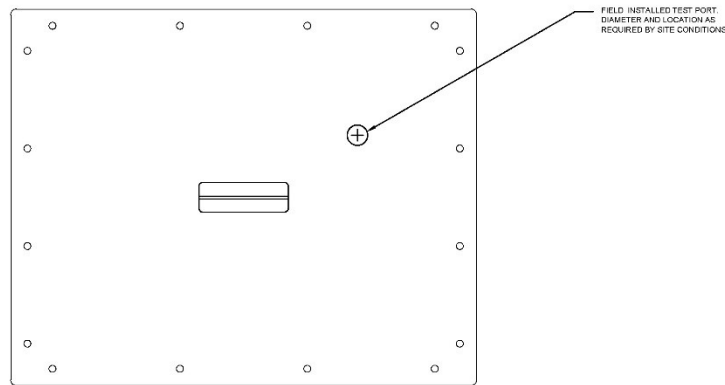

## MAINTENANCE GUIDELINES:

NFPA 96 in conjunction with local building codes should be referenced for inspection and cleaning requirements. The table in the cleaning procedure outlines NFPA 96 recommended inspection for grease buildup. It is recommended that grease containers and drain ports are inspected and emptied on an ongoing basis to reduce buildup.

## CLEANING PROCEDURE:

NFPA 96 recommends the entire exhaust system shall be inspected for grease buildup by a properly trained, qualified, and certified person(s) acceptable to the AHJ and in accordance with Table 11.4:

| Type or Volume of Cooking  | Inspection Frequency |
|--|----------------------|
| Systems serving solid fuel cooking operations  | Monthly              |
| Systems serving high-volume cooking operations, such as 24-hour cooking, charbroiling, or wok cooking              | Quarterly            |
| Systems serving moderate-volume cooking operations   | Semi-Annually        |
| Systems serving low-volume cooking operations, such as churches, day camps, seasonal businesses, or senior centers | Annually             |

Schedule of Inspection for Grease Buildup (NFPA 96)



199 Courtland Avenue ■ Concord, ON L4K 4T2, Canada  
TEL: 647.946.4770 ■ EMAIL: [sales@vaughanair.com](mailto:sales@vaughanair.com)