

Installation Instructions and Operation & Maintenance Manual

DuraDuct™ HXD

2HR Fire Rated Laboratory Exhaust & Hazardous Exhaust System
ASTM E119 | CAN/ULC-S101 Listed System

Do not install this system without completely reading the installation instructions. All details as noted in this document must be followed. For further information please contact VaughanAir. Do not use this system for kitchen exhaust applications.

Pennsylvania Avenue ■ Concord, ON L4K 4A6, Canada
TEL: 647.946.4770 ■ EMAIL: sales@vaughanair.com

CONTENTS

GENERAL INFORMATION	2
Product Features:	2
Tests Performed:	3
CONSTRUCTION DETAILS	3
Code Compliance:	7
Design Listing Information:	7
Handling Instructions:	7
Connection Details:	8
Flange Assembly Instructions – Hazardous/Laboratory Duct:	8
Common Duct (Manifold) Systems:	10
Dampers.....	10
SUPPORT METHODS AND DETAILS	11
Horizontal Supports:	11
Vertical Supports:	12
THROUGH-PENETRATION FIRESTOP SYSTEM.....	15
TERMINATIONS	17
FAN CONNECTIONS/HOOD ADAPTORS	17
ROOF PENETRATIONS	18
Roof penetration through curb:.....	18
WARRANTY	18

GENERAL INFORMATION

DuraDuct™ HXD is a segmented, pre-manufactured and non-combustible double wall fire rated duct suitable for hazardous exhaust systems. DuraDuct™ HXD is a zero-clearance system to all combustibles and non-combustible materials in accordance with ASTM E119 & CAN/ULC-S101 for a 2-hour fire exposure from inside or outside the assembly, suitable for use in systems where fire dampers are not allowed by code.

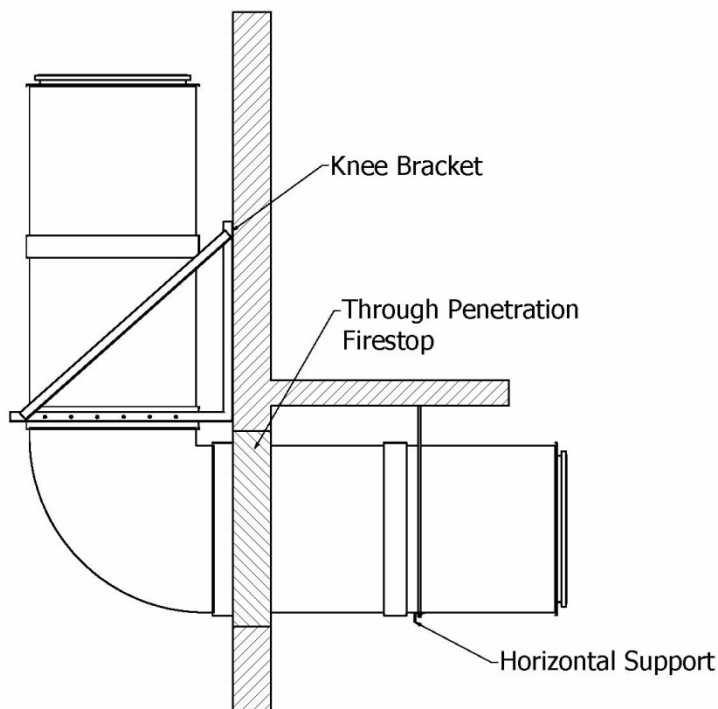

General Layout Detail

PRODUCT FEATURES:

- Zero Clearance to combustibles at any location
- Verified as IMC code compliant by Intertek code compliance report, CCRR-0421
- Thin footprint; 3-1/4" double wall design
- Mechanical protection of the insulating material inherent in the design
- All materials are inorganic and non-combustible
- Standard minimum 18-gauge stainless liner
- Fully welded inner duct liner option available for air tight systems
- Specialized fittings available

TESTS PERFORMED:

CAN/ULC-S101	Standard Methods of Fire Endurance Tests
ASTM E 119	Standard Test Methods for Fire Tests of Building Construction and Materials
ASTM E 814	Standard Test Method for Fire Tests of Through-Penetration Fire Stops
ASTM E 136	Standard Test Method for Behavior of Material in a Vertical Tube Furnace at 750°C (1382°F)
ASTM C 518	Standard Test Method for Steady-State Thermal Transmission Properties by Means of the Heat Flow Meter Apparatus
ASTM E 84	Standard Test Method for Surface Burning Characteristics of Building Materials
ANSI/ASHRAE/SMACNA 126	Method of Testing HVAC Ducts
ASME N510	Testing of Nuclear Air Treatment Systems
ASTM F36	Compressibility and Recovery of Gasket Materials
ASTM F152	Tension Testing of Non-Metallic Gasket Materials

CONSTRUCTION DETAILS

DuraDuct™ HXD has a 3-1/4” annular space between the inner liner and outer casing. It is constructed with a standard 18-gauge stainless liner, the outer casing of the system is offered in minimum 20 gauge galvanized or 22-gauge stainless steel construction. It is supplied with flange-to-flange connections and a field applied flange cover assembly.

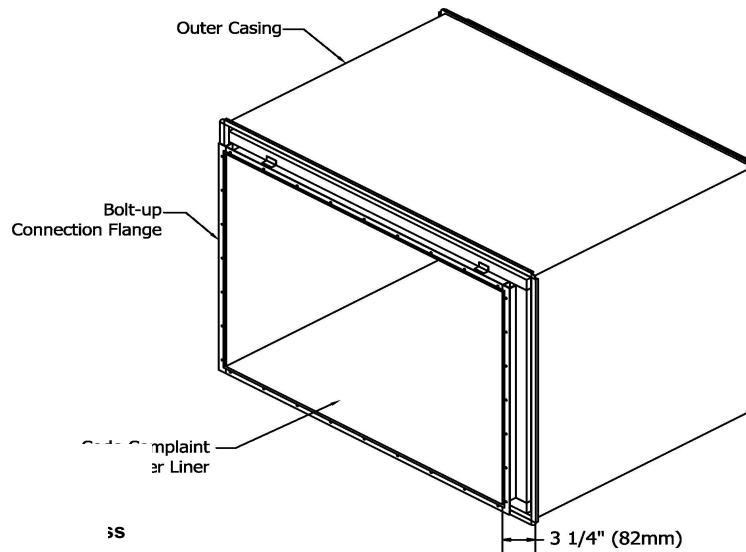

General Construction Detail

Materials: Inner Liner: 18ga 304 Stainless steel - Standard
18ga 316 Stainless steel - Premium

Outer Casing: 20ga Galvanized steel - Standard
22ga 304 Stainless steel - Premium
22ga 316 Stainless steel - Premium

Angle Flanges: 1-1/2" x 1/8" painted mild steel structural angle - Standard
1-1/2" x 1/8" 304 Stainless steel structural angle - Premium
1-1/2" x 1/8" 316 Stainless steel structural angle – Premium

Duct Weight: 10 lbs/ft²

Standard Fittings: See the attached pages for DuraDuct™ HXD standard fittings and dimensions. Non-Standard fittings, fittings sizes, and fitting configurations are available for a premium. Contact VaughanAir for details.

Construction Inner Duct (A)
Casing (B) = A + 6.5"
O.D at Joint (C) = A + 8.5

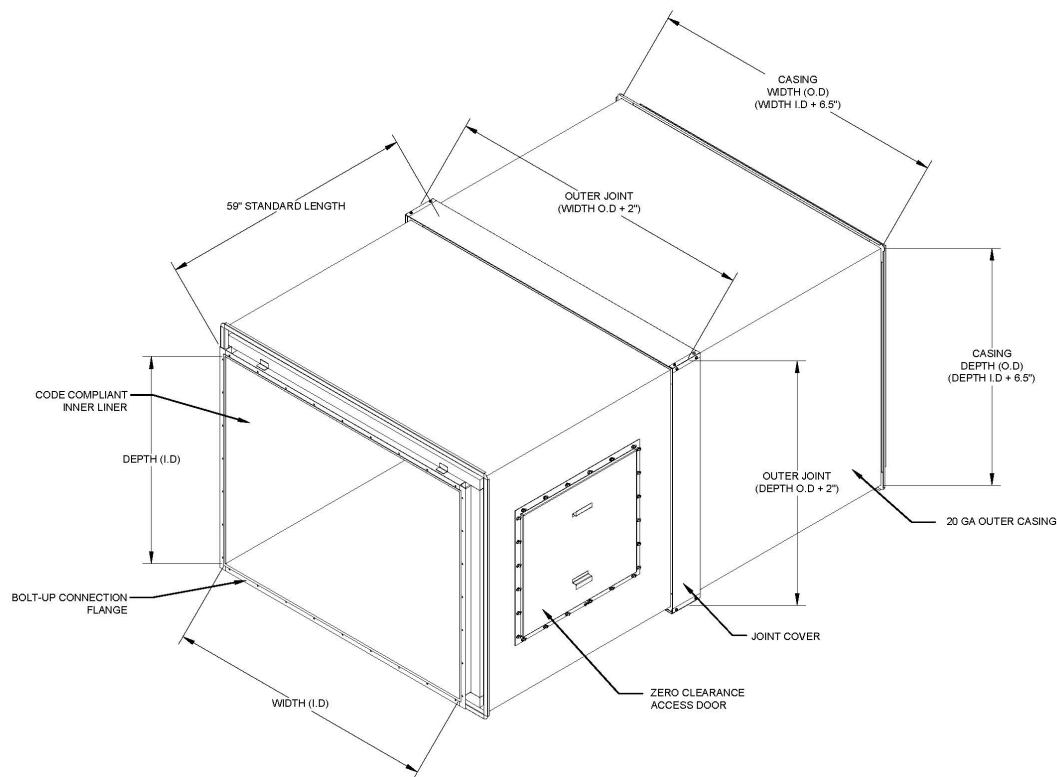

DuraDuct™ HXD Construction Detail

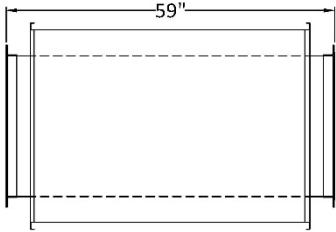
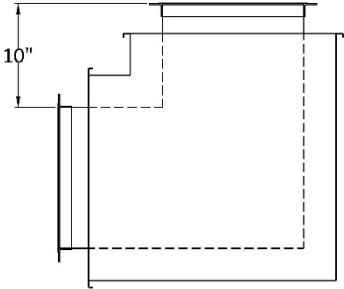
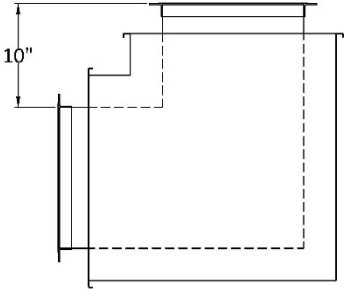
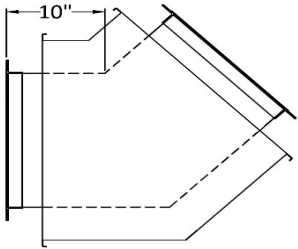
	<p>Straight Duct</p> <p>Standard Length = 59" Minimum Length = 14" ** Contact VaughanAir when smaller duct sizes are required.</p>
	<p>90 Degree Square Elbow</p> <p>Minimum Standard Throat = 10"</p>
	<p>90 Degree Radius Elbow</p> <p>Minimum Standard Throat = 10" Standard Radius = W</p>
	<p>45 Degree Elbow</p> <p>Minimum Standard Throat = 10"</p>

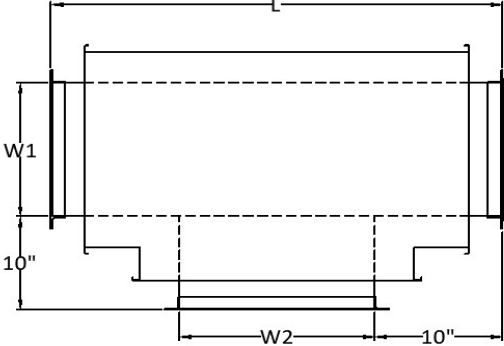
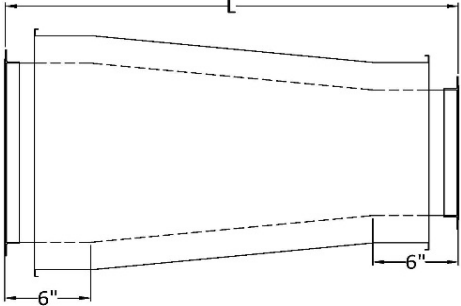
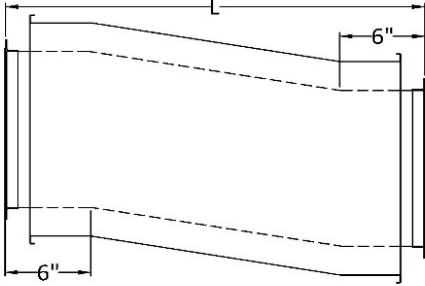
	<p>Straight Duct with Tap</p> <p>Minimum Standard Throat = 10" Length (L) = W2 + 20"</p>
	<p>Transition</p> <p>Minimum Standard length (L) = 30"</p>
	<p>Offset</p> <p>Minimum Standard Length (L) = 30"</p>

CODE COMPLIANCE:

The DuraDuct™ HXD system, installed as per the ASTM E119 & CAN/ULC-S101 design listing, meets the requirements of the following codes: National Building Code of Canada, International Mechanical Code, International Building Code and NFPA 90A/90B.

Code compliance for use as a hazardous duct per the requirements of the IMC is documented in Intertek Code Compliance Research Report CCRR-0421.

DESIGN LISTING INFORMATION:

DuraDuct™ HXD is listed in accordance with ASTM E199 & CAN/ULC-S101 by Intertek. ETL Listing number is DSB/FMF 120-08 and is included in CCRR-0421.

HANDLING INSTRUCTIONS:

DuraDuct™ HXD is a robust system, however, care should be taken in handling the ductwork. All fittings are shipped skidded and shrink wrapped. Each component should be inspected for damage. If damage has occurred:

- Notify VaughanAir and the freight company upon receipt of the goods.
- Record damaged items on the bill of lading.
- Send pictures of damaged items to VaughanAir.

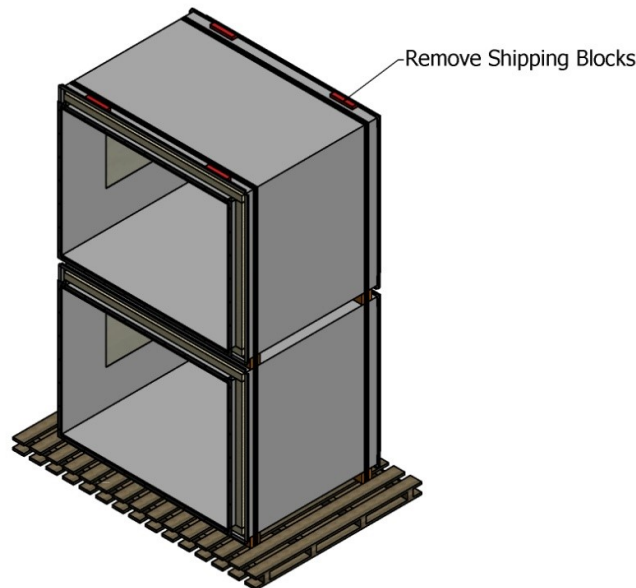

Shipment Configuration

NOTE: All DuraDuct™ products must be stored in a dry location protected from weather and possible damage from site construction. Exposure to weather or site damage to DuraDuct™ products may affect product performance and or void the warranty of the product.

CONNECTION DETAILS:

All components are supplied with flanged connections. All flanged connections are designed alike providing a quick and trouble-free installation. All joint gasket, insulation, sealant, nuts, bolts, washers and screws are provided to complete the single-source design.

FLANGE ASSEMBLY INSTRUCTIONS – HAZARDOUS/LABORATORY DUCT:



Step 1:

- 1) Thoroughly clean the connection flange of any oil or debris (a solvent based degreaser may be used) to ensure a positive bond between the gasket and steel flange.
- 2) Install the CRG joint gasket by removing the paper backing and applying the gasket flush to the outer edge of the inner liner flange. For round duct configurations, overlap of the gasket should be made at the top portion of the duct and centered between bolt holes. Be sure not to stretch the gasket while you apply it to the steel flange.
- 3) CRG joint gasket does not require any specific cure time prior to operation.

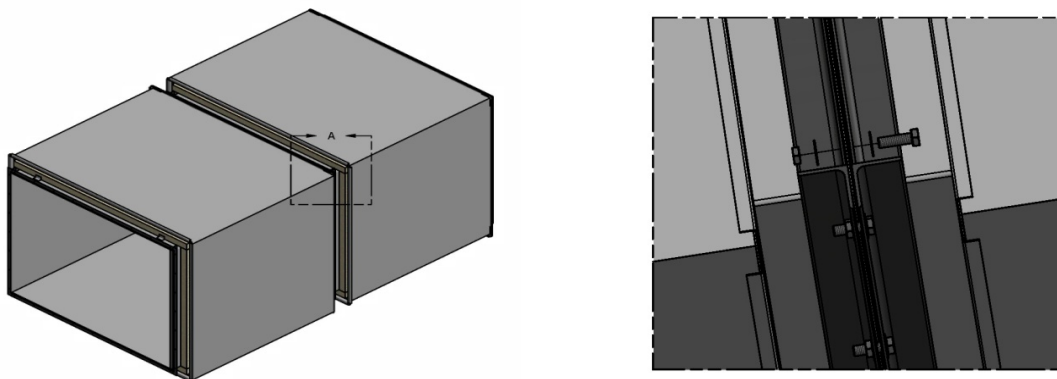

Connection Detail

Step 2:

Connect each section using the supplied 5/16" bolt assemblies. A nut, bolt and two flat washers are provided for each bolt hole. Be sure to not disturb the sealant when assembling. Tighten each bolt assembly making sure to check each fastener prior to moving on to step 3. Bolt assembly to be torqued to 75 to 95 lbf-in.

Tip: A drift pin is helpful to locate the bolt holes.

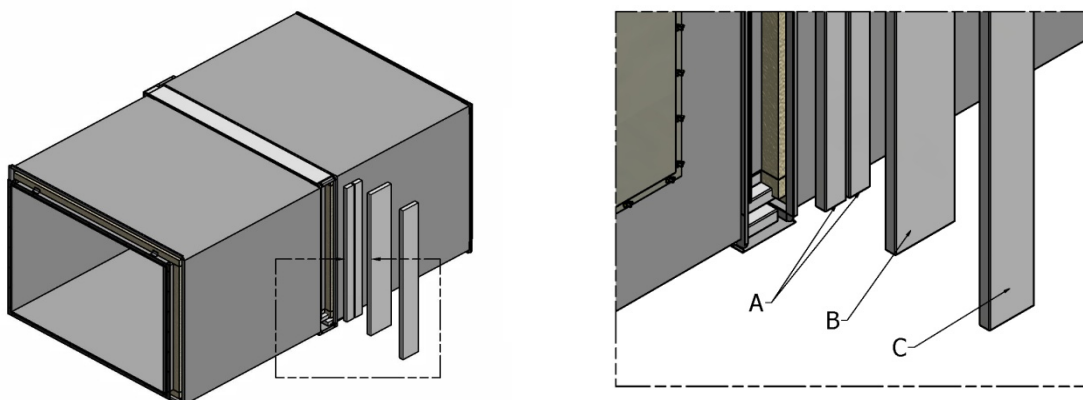

Joint Insulation Detail

Step: 3

- Install the first insulation layer (A), Nominal 4" wide insulation between the internal duct insulation and the inner duct flange. Be sure all voids are filled with insulation. Overlap the vertical and horizontal insulation with a 1/2" compression on each end and stagger to the outside length of the inner duct flanges.
- Install the second layer (B), nominal 8" wide insulation tucked under the duct edges (work the insulation well into the joint and pack down to the flange. Be sure all voids are filled with insulation. Overlap the vertical and horizontal insulation with a 1/2" compression on each end and stagger to the outside length of the inner duct flanges. This insulation layer should overlap the seam in Step a).
- Install the third layer (C), nominal 6" wide insulation between the duct edges and into the hat channel. Be sure all voids are filled with insulation. Overlap the vertical and horizontal insulation with a 1/2" compression on each end and stagger to the outer board of the outer duct liner.

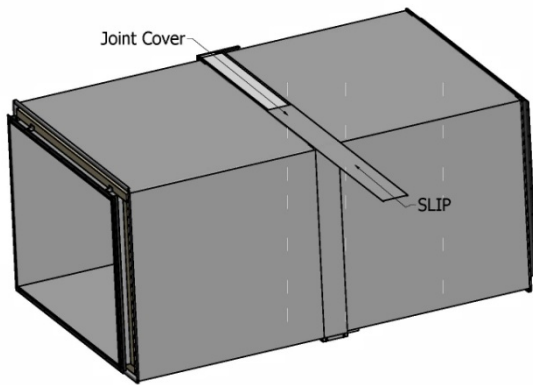

Detail A

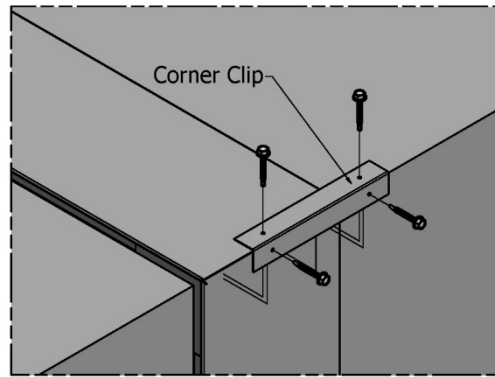

Detail B

Joint Cover Installation Detail

Step 4:

Install the joint cover as shown in detail A. Install corner clips using 4, #10 x 1/2" long hex head Tek screws as shown in detail B. Consult VaughanAir when duct is to be installed tight to the ceiling.

COMMON DUCT (MANIFOLD) SYSTEMS:

DuraDuct HXD is capable of tying together multiple hoods/systems in a single common duct. Make sure to follow the installation drawings closely for specific details regarding these systems.

DAMPERS:

Dampers should be listed for their intended use in duct systems. The installation shall be compatible with the duct and should be installed in accordance with the manufacturer's recommendations conforming to all applicable local codes.

SUPPORT METHODS AND DETAILS

HORIZONTAL SUPPORTS:

The supports outlined in the chart below will provide for joint alignment and support for duct horizontal applications. Spacing as noted in the chart is required. The horizontal supports shall be secured to fire resistance rated structural members of the building, which can adequately support the weight of the duct system. The duct cradles are based on support rods being a maximum of 1" from the side of the duct. Consult VaughanAir if the support rods are to be installed further from the duct than noted prior to installation.

Perimeter of Duct (Inside Dimension)	Max Duct Width (Inside Dimension)	Rod Diameter	Cradle Size	Anchor Embedment Depth	Hanger Spacing
Up to 48"	12"	3/8"	2" x 2" x 1/4"	1-5/8"	59" o.c.
Up to 72"	24"	1/2"	2" x 2" x 3/8"	2-1/4"	59" o.c.
Up to 108"	36"	5/8"	2-1/2" x 2-1/2" x 3/8"	2-3/4"	59" o.c.
Up to 144"	48"	5/8"	3" x 3" x 3/8"	2-3/4"	59" o.c.
Up to 212"	60"	3/4"	3-1/2" x 3-1/2" x 1/2"	3-1/4"	59" o.c.

Notes:

- 1) Vertical rods are based on 36 ksi (250MPa) yield strength.
- 2) Vertical rod location shall be maximum 1" from the outer side wall of the duct.
- 3) Duct cradle is based on 44 ksi (300MPa) yield strength.
- 4) Duct cradle length shall extend minimum 1" beyond outer edge of threaded rod.
- 5) Anchors to be drop-in or wedge type anchors.
- 6) Please contact VaughanAir if duct supports are to deviate from the guidelines listed above for review prior to installation.
- 7) Supports are supplied by others.

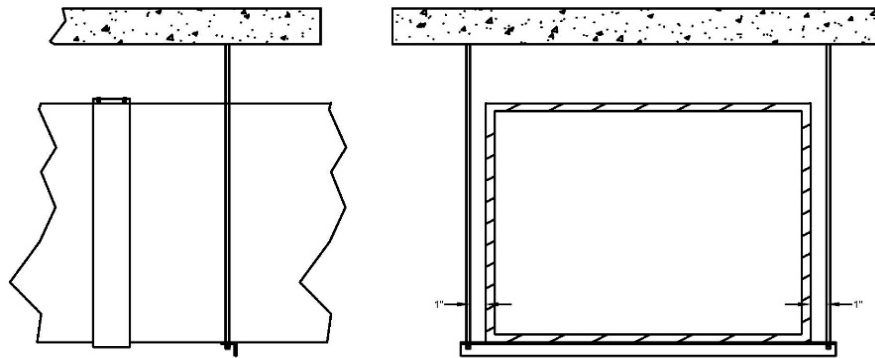

Cradle/Rod Location Detail

VERTICAL SUPPORTS:

Knee Brackets - The knee brackets supplied by other should maintain a 45° angle, if this is impractical consult with VaughanAir prior to installation. The vertical supports shall be secured to fire resistance rated structural members of the building, which can adequately support the weight of the duct system.

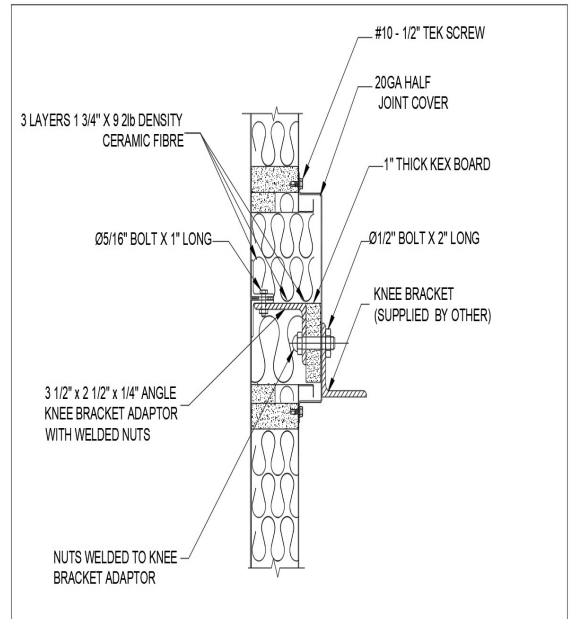
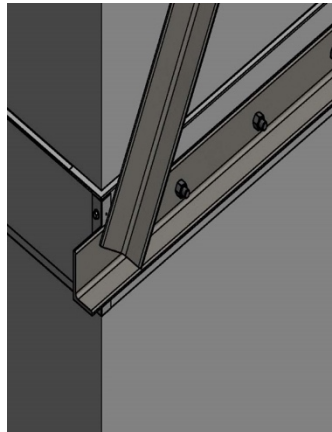
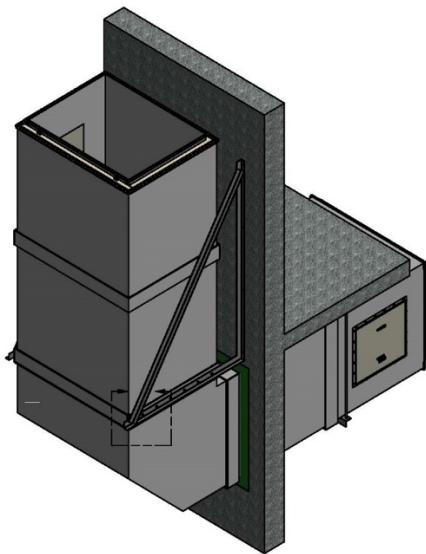

Typical Knee Bracket – Vertical Support

Perimeter of Duct	Minimum Duct Depth	Support Limit
Up to 48"	10"	30 ft
Up to 72"	12"	
Up to 108"	18"	
Up to 144"	24"	
Up to 212"	36"	
Standard Knee Bracket Angle Size	3" x 2" x 1/4"	

Notes: Contact VaughanAir for assistance with anchor size, quantity and embedment depth.

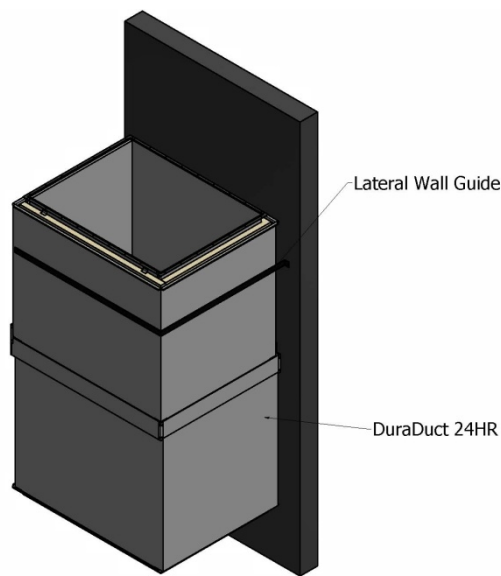

Lateral Wall Guide Detail

Lateral Guide Supports - Lateral guide supports supplied by other are installed every 20ft to ensure alignment during vertical installation of the DuraDuct HXD. The vertical guide supports shall be secured to fire resistance rated structural members of the building, which can adequately support the duct system. Contact VaughanAir for design assistance with the vertical guide supports.

Notes: Please contact VaughanAir if duct supports are to deviate from the guidelines listed above for review prior to installation.

Floor Supports - Floor support channels must overlap the edge of the opening by a minimum of 3” (75mm). The floor support channel should be shimmed (steel shims) as necessary to ensure that the channel is supporting the load of the duct. The floor supports shall sit on a structural slab or member of the building, which can adequately support the weight of the duct system.

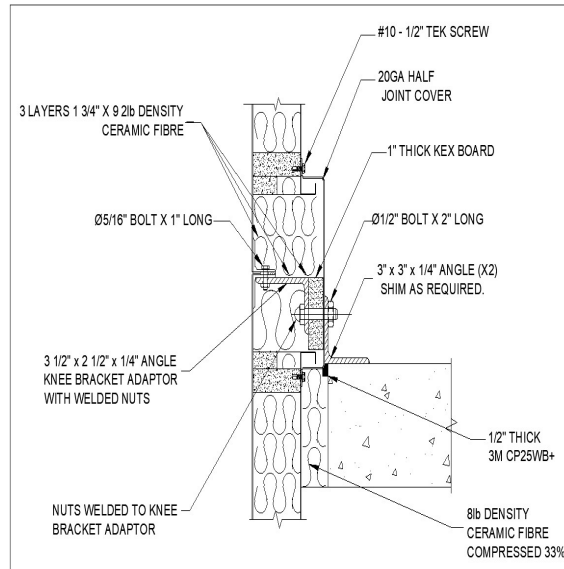
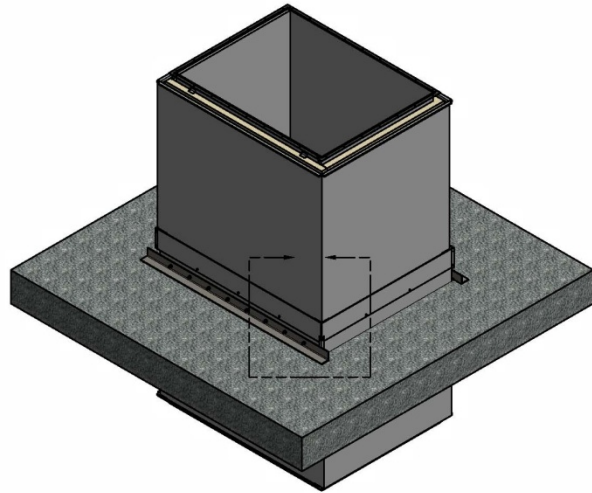

Typical Floor Support – Vertical Support

Perimeter of Duct	Minimum Duct Depth	Support Limit
Up to 48"	10"	30 ft
Up to 72"	12"	
Up to 108"	18"	
Up to 144"	24"	
Up to 212"	36"	
Standard Floor Support Angle Size	3" x 3" x 1/4"	

Notes: Please contact VaughanAir if duct supports are to deviate from the guidelines listed above for review prior to installation.

THROUGH-PENETRATION FIRESTOP SYSTEM

THE FIRE STOPPING IS AN INTEGRAL PART OF OUR DUCT LISTINGS AND THE FOLLOWING MUST BE FOLLOWED. ALL PENETRATIONS THRU FIRE RATED WALLS AND FLOORS MUST BE FIRE STOPPED AS SHOWN.

- 1) The annular space between the duct and the structure shall be completely filled with 8lb/ft³ (128kg/m³) ceramic batt insulation leaving a 1/2" (12mm) gap back from the slab face. 33% compression is required to fill the annular space.
- 2) Fill the 1/2" (12mm) recess at the top of the packing material with type 3M CP25WB+ flush to the slab face. No overlap onto the supporting construction is required.
- 3) Complete the joint protection in accordance with the floor support instructions.

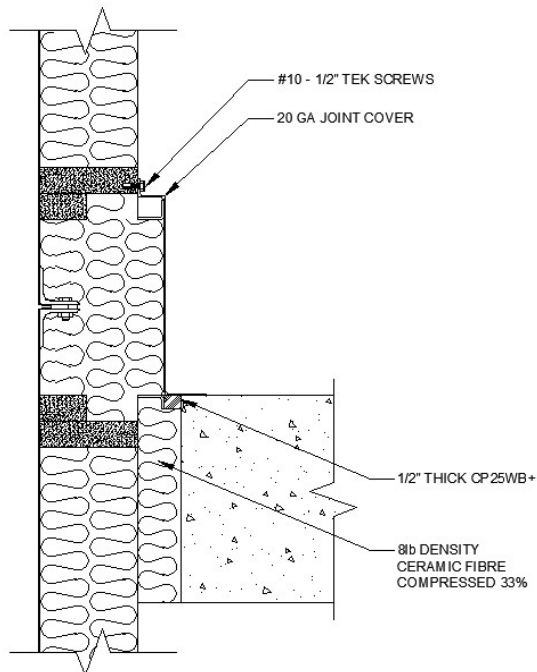

Typical Firestop Detail at Slab

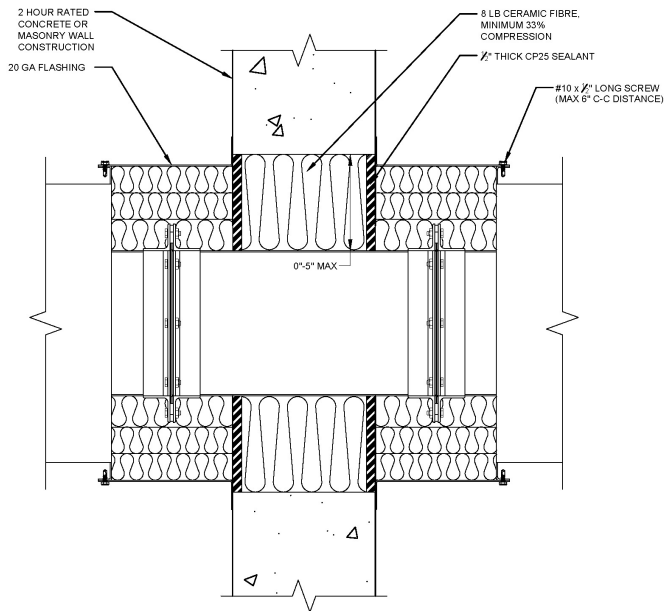

Typical Firestop Detail through a Concrete or Masonry Wall

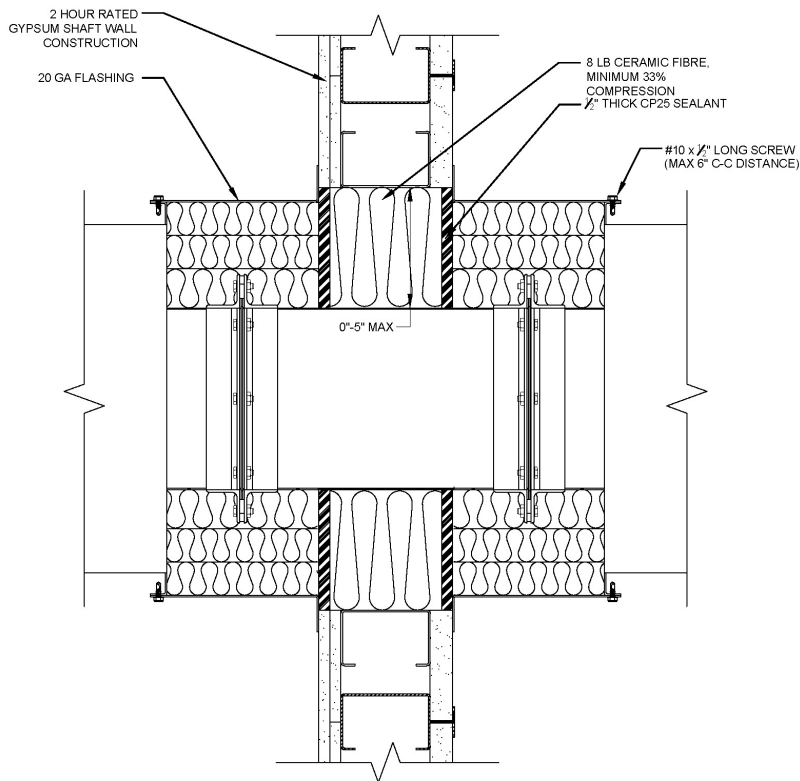

Typical Firestop Detail through a Shaft Wall

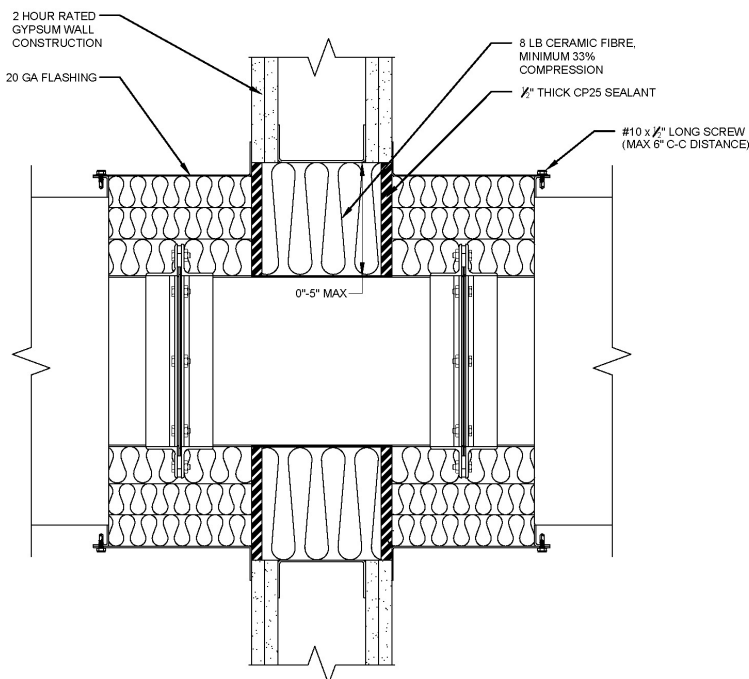

Typical Firestop Detail through a Gypsum Wall with Steel Studs

TERMINATIONS

To support a quick and easy installation, DuraDuct™ HXD, includes special termination components as a complete system offering. The HXD system may terminate vertically or horizontally through the roof of the building or on an exterior wall as determined by the specified fan exhaust system. Reference your local code requirements for details.

FAN CONNECTIONS/HOOD ADAPTORS

The DuraDuct™ HXD design incorporates special adaptors when required to attach to all types of exhaust systems and provide a fast and easy installation. An assortment of exhaust equipment exists in the market for ventilation/hazardous exhaust applications and this should be coordinated with VaughanAir project management on a job-by-job basis.

ROOF PENETRATIONS

ROOF PENETRATION THROUGH CURB:

Roof curb flashing should be installed in accordance with local codes and requirements where applicable.

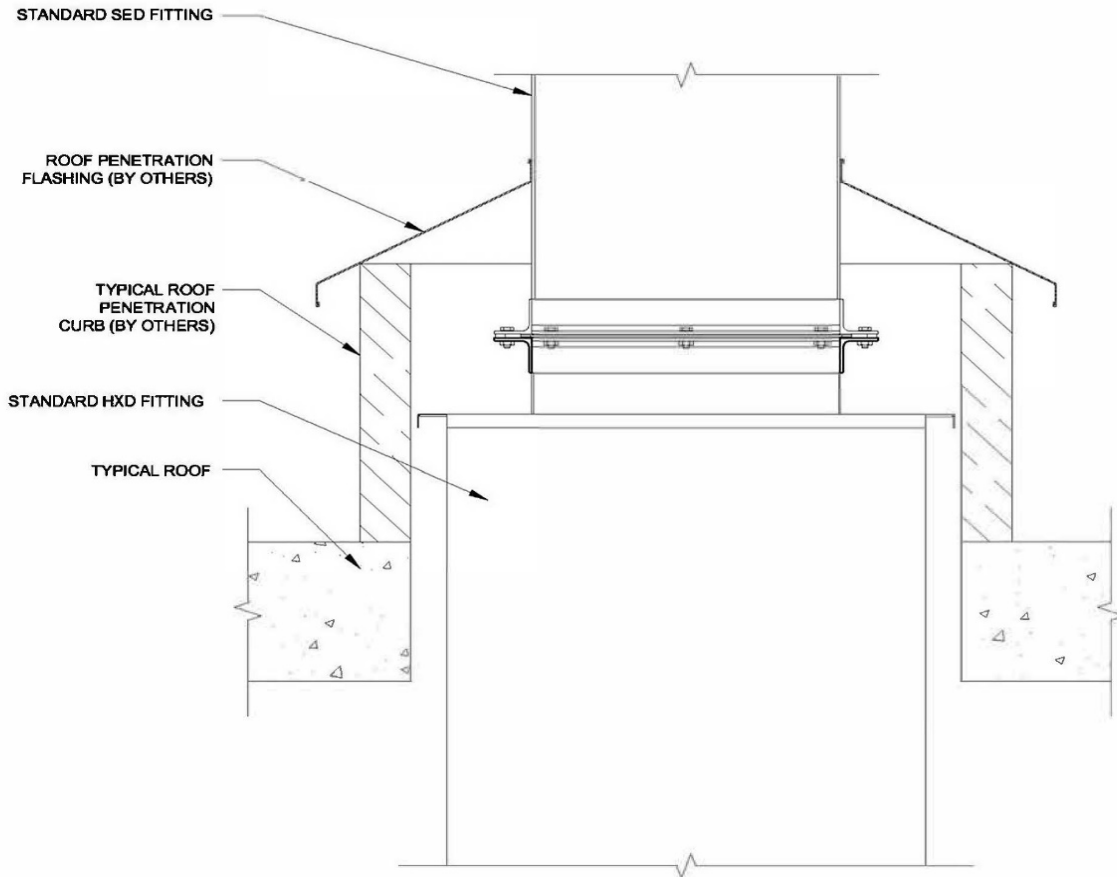

Typical Roof Penetration Detail

WARRANTY

These products have a limited lifetime warranty. Please contact VaughanAir or your local representative for further information.



Pennsylvania Avenue ■ Concord, ON L4K 4A6, Canada
TEL: 647.946.4770 ■ EMAIL: sales@vaughanair.com